



National Aeronautics and
Space Administration

Educational Product

Educators | Grades 5–8

STARDUST

ACTIVITY GUIDE

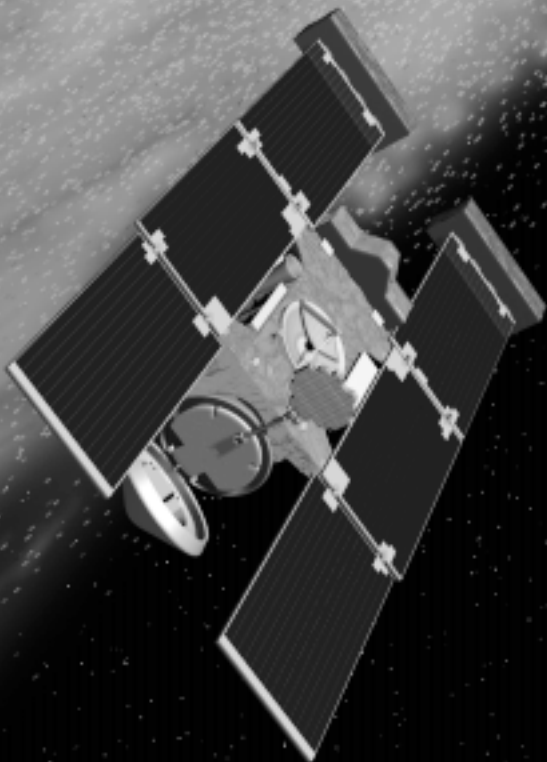

Think
SMALL
in a
BIG way

A DISCOVERY MISSION



National Aeronautics and
Space Administration

Jet Propulsion Laboratory
California Institute of Technology
Pasadena, California

JPL 400-855 8/99
EG-1999-08-010-JPL

Think **SMALL** in a **BIG** Way

**An Educator's Activity Guide for the STARDUST Mission
for Grades 5-8**



Brought to you by
National Aeronautics and Space Administration
Jet Propulsion Laboratory, California Institute of Technology
and
The STARDUST Opportunity and Outreach Team:

Challenger Center for Space Science Education

The JASON Foundation for Education

Omniplex at Kirkpatrick Science and Air Space Museum

STARDUST™ is a trademark of the California Institute of Technology.
Images copyright 1999 Jet Propulsion Laboratory, California Institute of
Technology. All rights reserved.

Permission is given to reproduce this Activity Guide
for the preparation of educational materials that are not for profit.

Acknowledgments

This activity guide has been developed by the STARDUST Opportunity and Outreach Team as part of the Jet Propulsion Laboratory's STARDUST mission educational outreach program. Team members include:

Challenger Center For Space Science Education

JASON Foundation for Education

Omniplex at Kirkpatrick Science and Air Space Museum

Advisory Board Members

Donald Brownlee, Ph.D.
STARDUST Principal Investigator
University of Washington

Mary Gromko
State Science Coordinator
Colorado Department of Education

Ellen Hardwick, Ph.D.
Aerospace Education Services Program
National Aeronautics and Space Administration

Wendell Mohling, Ph.D.
Associate Executive Director of
Conventions and Professional Programs
National Science Teachers Association

A special thanks for the activities that were developed and contributed to this activity guide by the Education Outreach Team members:

“Comet Cratering”—Challenger Center for Space Science Education.

“Cookin’ Up a Comet”—this activity most likely originated from Dennis Schatz at the Pacific Science Center or Lynn Bondurant at NASA Lewis Research Center. This version was compiled by Challenger Center.

“The Incredible Edible Comet”—Challenger Center developed this activity based on a recipe from Kirkpatrick Science and Air and Space Museum at Omniplex, Oklahoma City, Oklahoma.

“Famous Comets”—developed by Challenger Center

“Voyage of Discovery”—this activity is based on Challenger Center’s *Voyages Across the Nation*, a partnership between Challenger Center, the Smithsonian Institution, and NASA.

“Feedback Loops”—adapted from the JASON Core Curriculum, prepared by the National Science Teacher’s Association.

“Navigation Simulation”—adapted from the JASON Core Curriculum.

“Candy Model Spacecraft”—developed by Challenger Center.

“Egg Drop Sample Return Capsule”—adapted from NASA Spacelink.

“Aerogel Clay Collector Activity Overview”—developed by Challenger Center based on the aerogel-10 activity from Kirkpatrick Science and Air and Space Museum at Omniplex.

“Paint by the Numbers”—from the NASA publication *Space Based Astronomy Teacher’s Guide*.

Table of Contents

About This Guide	vii
National Science & Mathematics Standards Matrix	ix
Think SMALL in a Big Way	1
Activity: Comet Cratering.	7
<i>Student-centered activity</i>	
<i>Models impact cratering.</i>	
Comet Basics	15
Activity: Cookin' Up a Comet.	16
<i>Teacher-centered demonstration</i>	
<i>Dramatically and physically models a comet.</i>	
Activity: The Incredible Edible Comet	19
<i>Student activity</i>	
<i>Makes a fun, tasty snack and model.</i>	
Activity: Famous Comets	21
<i>Student research and creative writing activity</i>	
<i>Offers historically significant perspective on comets.</i>	
Comet Origins and Travels	27
Activity: Voyage of Discovery.	28
<i>Outdoor teacher-guided activity</i>	
<i>Models the size of the planets and the distances between them.</i>	
Activity: Elliptical Orbits.	37
<i>Student activity</i>	
<i>Draws geometric shape: the ellipse.</i>	

STARDUST’s Rendezvous with Wild 2 Comet	43
Activity: Feedback Loops.	44
<i>Cooperative student activity</i>	
<i>Uses communication skills and technology.</i>	
Activity: Navigation Simulation	47
<i>Cooperative student activity</i>	
<i>Uses communication skills, technology, and mapping skills.</i>	
Spacecraft Design & Testing	51
Activity: Candy Model Spacecraft.	52
<i>Student activity</i>	
<i>Aids internalization of spacecraft technology, parts with function</i>	
Activity: Egg Drop Sample Return Capsule	55
<i>Cooperative student activity</i>	
<i>Designs, builds, and tests a sample return capsule.</i>	
Technology for Studying Comets.	59
Activity: Aerogel Clay Collector Activity Overview	61
<i>Cooperative student activity</i>	
<i>Designs an experiment; builds and tests a device; requires peer review of experiment design; and replicates experiment results.</i>	
Activity: Paint by the Numbers	84
<i>Cooperative student activity</i>	
<i>Uses binary number system to code and decode images.</i>	
Fact Sheets	89
<i>Impact Crater Fact Sheet</i>	
<i>Comet Fact Sheet</i>	
<i>Kuiper Belt & Oort Cloud Fact Sheet</i>	
<i>STARDUST Mission Fact Sheet</i>	
<i>STARDUST Spacecraft Fact Sheet</i>	
<i>Aerogel Fact Sheet</i>	
Vocabulary	103
Resources	105

About This Guide

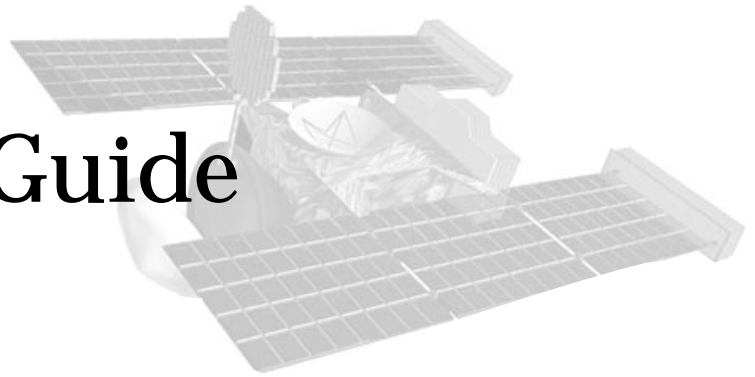

This guide focuses on parts of the Solar System that do not get much attention: the small bodies of the Solar System, namely asteroids, meteoroids, and comets. These small bodies play a significant role in the formation of the Solar System, and they can leave a lasting impact in their own right. For more information about the basics of asteroids, meteoroids, and comets and their significance, see the section Think SMALL in a Big Way on page 1.

Small bodies tie into the *National Science Education Standards* by the National Research Council and *Curriculum and Evaluation Standards for School Mathematics* by the National Council of Teachers of Mathematics. To see how the activities have been correlated to the national standards, consult the Activity Matrix on page ix.

Each section contains background information and activities that support the section topic. The guide is broken into sections that touches upon various facets of a mission to explore Comet Wild 2 (pronounced “Vilt,” after its discoverer). The first dedicated U.S. mission to a comet is the STARDUST mission, launched February 7, 1999. For more information about STARDUST, see page 5. Teachers can use this guide with great flexibility, focusing on any aspect of a mission that most suits his or her curriculum, current events, etc. By picking at least one activity from each section, students gain a breadth of understanding about mission planning and execution couched in a real-world context of an actual mission, STARDUST.

The first section starts by exploring the current thinking about comet anatomy and structure. The second section part looks at where comets reside in the Solar System and their orbits. The third section examines some of the intricacies of navigating a spacecraft to a comet, followed by the fourth section that deals with spacecraft design and testing. Finally, students investigate aspects of spacecraft technology for studying Comet Wild 2. This includes transmitting data and designing a device to capture particles to bring back for Earth studies.

Fact Sheets are located at the end of the guide since several activities make use of the same ones. For the teacher selecting just one or two activities to do in class, these Fact Sheets can be used with any activity to overview basic concepts. The vocabulary at the back of the guide is another such handy reference. It contains concise definitions of key vocabulary for small bodies. As missions progress, updates occur continuously on the Internet. The latest information can be found on the NASA mission homepages listed in the Resources section at the end of the activity guide.

While teachers are welcome to pick and choose among the activities, we have structured the guide so that those teachers, who are so inclined, can simulate the STARDUST mission. We suggest kicking off a STARDUST unit with the teacher demonstration Cookin' Up a Comet and other activities from Comet Basics. Hold a "mission briefing" tasking students to work in teams to design and implement the STARDUST mission. Use activities from each unit to address different aspects of the mission. The following is a logical sequence of mission events and corresponding activities.

MISSION EVENT	ACTIVITY
Mission briefing	STARDUST Fact Sheet
Spacecraft design	Candy Model Spacecraft
Comet orbit	Elliptical Orbits
Spacecraft navigation	Navigation Simulation
Comet rendezvous	Cookin' Up a Comet
Data transmission	Paint by the Numbers
Particle capture	Aerogel Clay Collector
Sample return	Egg Drop Sample Return Capsule

**Activity Matrix
for National Science Education Standards
and Curriculum and Evaluation Standards for School Mathematics
Grades 5-8**

	NATIONAL SCIENCE STANDARDS																																																																																																																																																																																																																																																																																																																																																																																																																																																																																																																																																																																																																																		
	Unifying Concepts and Processes																																																																																																																																																																																																																																																																																																																																																																																																																																																																																																																																																																																																																																		
	Systems, order, and organization																	Evidence, models, and explanation																	Change, constancy, and measurement																	Evolution and equilibrium																	Form and function																	Science as Inquiry																	Abilities necessary to do scientific inquiry																	Understanding about scientific inquiry																	Physical Science																	Properties and changes of properties in matter																	Motions and forces																	Transfer of energy																	Earth and Space Science																	Structure of the Earth system																	Earth's history																	Earth in the Solar System																	Science and Technology																	Abilities of technological design																	Understanding about science and technology																	Science in Personal and Social Perspectives																	Science and technology in society																	History and Nature of Science																	Science as human endeavor																	Nature of science																	History of science																	National Mathematics Standards																	Mathematics as Problem Solving																	Mathematics as Communication																	Mathematics as Reasoning																	Mathematical Connections																	Number and Number Relationships																	Computation and Estimation																	Patterns and Functions																	Algebra																	Geometry																	Measurement															
	Evidence, models, and explanation																	Change, constancy, and measurement																	Evolution and equilibrium																	Form and function																	Science as Inquiry																	Abilities necessary to do scientific inquiry																	Understanding about scientific inquiry																	Physical Science																	Properties and changes of properties in matter																	Motions and forces																	Transfer of energy																	Earth and Space Science																	Structure of the Earth system																	Earth's history																	Earth in the Solar System																	Science and Technology																	Abilities of technological design																	Understanding about science and technology																	Science in Personal and Social Perspectives																	Science and technology in society																	History and Nature of Science																	Science as human endeavor																	Nature of science																	History of science																	National Mathematics Standards																	Mathematics as Problem Solving																	Mathematics as Communication																	Mathematics as Reasoning																	Mathematical Connections																	Number and Number Relationships																	Computation and Estimation																	Patterns and Functions																	Algebra																	Geometry																	Measurement																																
	Change, constancy, and measurement																	Evolution and equilibrium																	Form and function																	Science as Inquiry																	Abilities necessary to do scientific inquiry																	Understanding about scientific inquiry																	Physical Science																	Properties and changes of properties in matter																	Motions and forces																	Transfer of energy																	Earth and Space Science																	Structure of the Earth system																	Earth's history																	Earth in the Solar System																	Science and Technology																	Abilities of technological design																	Understanding about science and technology																	Science in Personal and Social Perspectives																	Science and technology in society																	History and Nature of Science																	Science as human endeavor																	Nature of science																	History of science																	National Mathematics Standards																	Mathematics as Problem Solving																	Mathematics as Communication																	Mathematics as Reasoning																	Mathematical Connections																	Number and Number Relationships																	Computation and Estimation																	Patterns and Functions																	Algebra																	Geometry																	Measurement																																																	
	Evolution and equilibrium																	Form and function																	Science as Inquiry																	Abilities necessary to do scientific inquiry																	Understanding about scientific inquiry																	Physical Science																	Properties and changes of properties in matter																	Motions and forces																	Transfer of energy																	Earth and Space Science																	Structure of the Earth system																	Earth's history																	Earth in the Solar System																	Science and Technology																	Abilities of technological design																	Understanding about science and technology																	Science in Personal and Social Perspectives																	Science and technology in society																	History and Nature of Science																	Science as human endeavor																	Nature of science																	History of science																	National Mathematics Standards																	Mathematics as Problem Solving																	Mathematics as Communication																	Mathematics as Reasoning																	Mathematical Connections																	Number and Number Relationships																	Computation and Estimation																	Patterns and Functions																	Algebra																	Geometry																	Measurement																																																																		
	Form and function																	Science as Inquiry																	Abilities necessary to do scientific inquiry																	Understanding about scientific inquiry																	Physical Science																	Properties and changes of properties in matter																	Motions and forces																	Transfer of energy																	Earth and Space Science																	Structure of the Earth system																	Earth's history																	Earth in the Solar System																	Science and Technology																	Abilities of technological design																	Understanding about science and technology																	Science in Personal and Social Perspectives																	Science and technology in society																	History and Nature of Science																	Science as human endeavor																	Nature of science																	History of science																	National Mathematics Standards																	Mathematics as Problem Solving																	Mathematics as Communication																	Mathematics as Reasoning																	Mathematical Connections																	Number and Number Relationships																	Computation and Estimation																	Patterns and Functions																	Algebra																	Geometry																	Measurement																																																																																			
	Science as Inquiry																																																																																																																																																																																																																																																																																																																																																																																																																																																																																																																																																																																																																																		
	Abilities necessary to do scientific inquiry																	Understanding about scientific inquiry																	Physical Science																	Properties and changes of properties in matter																	Motions and forces																	Transfer of energy																	Earth and Space Science																	Structure of the Earth system																	Earth's history																	Earth in the Solar System																	Science and Technology																	Abilities of technological design																	Understanding about science and technology																	Science in Personal and Social Perspectives																	Science and technology in society																	History and Nature of Science																	Science as human endeavor																	Nature of science																	History of science																	National Mathematics Standards																	Mathematics as Problem Solving																	Mathematics as Communication																	Mathematics as Reasoning																	Mathematical Connections																	Number and Number Relationships																	Computation and Estimation																	Patterns and Functions																	Algebra																	Geometry																	Measurement																																																																																																																					
	Understanding about scientific inquiry																	Physical Science																	Properties and changes of properties in matter																	Motions and forces																	Transfer of energy																	Earth and Space Science																	Structure of the Earth system																	Earth's history																	Earth in the Solar System																	Science and Technology																	Abilities of technological design																	Understanding about science and technology																	Science in Personal and Social Perspectives																	Science and technology in society																	History and Nature of Science																	Science as human endeavor																	Nature of science																	History of science																	National Mathematics Standards																	Mathematics as Problem Solving																	Mathematics as Communication																	Mathematics as Reasoning																	Mathematical Connections																	Number and Number Relationships																	Computation and Estimation																	Patterns and Functions																	Algebra																	Geometry																	Measurement																																																																																																																																						
	Physical Science																																																																																																																																																																																																																																																																																																																																																																																																																																																																																																																																																																																																																																		
	Properties and changes of properties in matter																	Motions and forces																	Transfer of energy																	Earth and Space Science																	Structure of the Earth system																	Earth's history																	Earth in the Solar System																	Science and Technology																	Abilities of technological design																	Understanding about science and technology																	Science in Personal and Social Perspectives																	Science and technology in society																	History and Nature of Science																	Science as human endeavor																	Nature of science																	History of science																	National Mathematics Standards																	Mathematics as Problem Solving																	Mathematics as Communication																	Mathematics as Reasoning																	Mathematical Connections																	Number and Number Relationships																	Computation and Estimation																	Patterns and Functions																	Algebra																	Geometry																	Measurement																																																																																																																																																																								
	Motions and forces																	Transfer of energy																	Earth and Space Science																	Structure of the Earth system																	Earth's history																	Earth in the Solar System																	Science and Technology																	Abilities of technological design																	Understanding about science and technology																	Science in Personal and Social Perspectives																	Science and technology in society																	History and Nature of Science																	Science as human endeavor																	Nature of science																	History of science																	National Mathematics Standards																	Mathematics as Problem Solving																	Mathematics as Communication																	Mathematics as Reasoning																	Mathematical Connections																	Number and Number Relationships																	Computation and Estimation																	Patterns and Functions																	Algebra																	Geometry																	Measurement																																																																																																																																																																																									
	Transfer of energy																	Earth and Space Science																	Structure of the Earth system																	Earth's history																	Earth in the Solar System																	Science and Technology																	Abilities of technological design																	Understanding about science and technology																	Science in Personal and Social Perspectives																	Science and technology in society																	History and Nature of Science																	Science as human endeavor																	Nature of science																	History of science																	National Mathematics Standards																	Mathematics as Problem Solving																	Mathematics as Communication																	Mathematics as Reasoning																	Mathematical Connections																	Number and Number Relationships																	Computation and Estimation																	Patterns and Functions																	Algebra																	Geometry																	Measurement																																																																																																																																																																																																										
	Earth and Space Science																																																																																																																																																																																																																																																																																																																																																																																																																																																																																																																																																																																																																																		
	Structure of the Earth system																	Earth's history																	Earth in the Solar System																	Science and Technology																	Abilities of technological design																	Understanding about science and technology																	Science in Personal and Social Perspectives																	Science and technology in society																	History and Nature of Science																	Science as human endeavor																	Nature of science																	History of science																	National Mathematics Standards																	Mathematics as Problem Solving																	Mathematics as Communication																	Mathematics as Reasoning																	Mathematical Connections																	Number and Number Relationships																	Computation and Estimation																	Patterns and Functions																	Algebra																	Geometry																	Measurement																																																																																																																																																																																																																																												
	Earth's history																	Earth in the Solar System																	Science and Technology																	Abilities of technological design																	Understanding about science and technology																	Science in Personal and Social Perspectives																	Science and technology in society																	History and Nature of Science																	Science as human endeavor																	Nature of science																	History of science																	National Mathematics Standards																	Mathematics as Problem Solving																	Mathematics as Communication																	Mathematics as Reasoning																	Mathematical Connections																	Number and Number Relationships																	Computation and Estimation																	Patterns and Functions																	Algebra																	Geometry																	Measurement																																																																																																																																																																																																																																																													
	Earth in the Solar System																	Science and Technology																	Abilities of technological design																	Understanding about science and technology																	Science in Personal and Social Perspectives																	Science and technology in society																	History and Nature of Science																	Science as human endeavor																	Nature of science																	History of science																	National Mathematics Standards																	Mathematics as Problem Solving																	Mathematics as Communication																	Mathematics as Reasoning																	Mathematical Connections																	Number and Number Relationships																	Computation and Estimation																	Patterns and Functions																	Algebra																	Geometry																	Measurement																																																																																																																																																																																																																																																																														
	Science and Technology																																																																																																																																																																																																																																																																																																																																																																																																																																																																																																																																																																																																																																		
	Abilities of technological design																	Understanding about science and technology																	Science in Personal and Social Perspectives																	Science and technology in society																	History and Nature of Science																	Science as human endeavor																	Nature of science																	History of science																	National Mathematics Standards																	Mathematics as Problem Solving																	Mathematics as Communication																	Mathematics as Reasoning																	Mathematical Connections																	Number and Number Relationships																	Computation and Estimation																	Patterns and Functions																	Algebra																	Geometry																	Measurement																																																																																																																																																																																																																																																																																																																
	Understanding about science and technology																	Science in Personal and Social Perspectives																	Science and technology in society																	History and Nature of Science																	Science as human endeavor																	Nature of science																	History of science																	National Mathematics Standards																	Mathematics as Problem Solving																	Mathematics as Communication																	Mathematics as Reasoning																	Mathematical Connections																	Number and Number Relationships																	Computation and Estimation																	Patterns and Functions																	Algebra																	Geometry																	Measurement																																																																																																																																																																																																																																																																																																																																	
	Science in Personal and Social Perspectives																																																																																																																																																																																																																																																																																																																																																																																																																																																																																																																																																																																																																																		
	Science and technology in society																	History and Nature of Science																	Science as human endeavor																	Nature of science																	History of science																	National Mathematics Standards																	Mathematics as Problem Solving																	Mathematics as Communication																	Mathematics as Reasoning																	Mathematical Connections																	Number and Number Relationships																	Computation and Estimation																	Patterns and Functions																	Algebra																	Geometry																	Measurement																																																																																																																																																																																																																																																																																																																																																																			
	History and Nature of Science																																																																																																																																																																																																																																																																																																																																																																																																																																																																																																																																																																																																																																		
	Science as human endeavor																	Nature of science																	History of science																	National Mathematics Standards																	Mathematics as Problem Solving																	Mathematics as Communication																	Mathematics as Reasoning																	Mathematical Connections																	Number and Number Relationships																	Computation and Estimation																	Patterns and Functions																	Algebra																	Geometry																	Measurement																																																																																																																																																																																																																																																																																																																																																																																																					
	Nature of science																	History of science																	National Mathematics Standards																	Mathematics as Problem Solving																	Mathematics as Communication																	Mathematics as Reasoning																	Mathematical Connections																	Number and Number Relationships																	Computation and Estimation																	Patterns and Functions																	Algebra																	Geometry																	Measurement																																																																																																																																																																																																																																																																																																																																																																																																																						
	History of science																	National Mathematics Standards																	Mathematics as Problem Solving																	Mathematics as Communication																	Mathematics as Reasoning																	Mathematical Connections																	Number and Number Relationships																	Computation and Estimation																	Patterns and Functions																	Algebra																	Geometry																	Measurement																																																																																																																																																																																																																																																																																																																																																																																																																																							
	National Mathematics Standards																																																																																																																																																																																																																																																																																																																																																																																																																																																																																																																																																																																																																																		
	Mathematics as Problem Solving																	Mathematics as Communication																	Mathematics as Reasoning																	Mathematical Connections																	Number and Number Relationships																	Computation and Estimation																	Patterns and Functions																	Algebra																	Geometry																	Measurement																																																																																																																																																																																																																																																																																																																																																																																																																																																																									
	Mathematics as Communication																	Mathematics as Reasoning																	Mathematical Connections																	Number and Number Relationships																	Computation and Estimation																	Patterns and Functions																	Algebra																	Geometry																	Measurement																																																																																																																																																																																																																																																																																																																																																																																																																																																																																										
	Mathematics as Reasoning																	Mathematical Connections																	Number and Number Relationships																	Computation and Estimation																	Patterns and Functions																	Algebra																	Geometry																	Measurement																																																																																																																																																																																																																																																																																																																																																																																																																																																																																																											
	Mathematical Connections																	Number and Number Relationships																	Computation and Estimation																	Patterns and Functions																	Algebra																	Geometry																	Measurement																																																																																																																																																																																																																																																																																																																																																																																																																																																																																																																												
	Number and Number Relationships																	Computation and Estimation																	Patterns and Functions																	Algebra																	Geometry																	Measurement																																																																																																																																																																																																																																																																																																																																																																																																																																																																																																																																													
	Computation and Estimation																	Patterns and Functions																	Algebra																	Geometry																	Measurement																																																																																																																																																																																																																																																																																																																																																																																																																																																																																																																																																														
	Patterns and Functions																	Algebra																	Geometry																	Measurement																																																																																																																																																																																																																																																																																																																																																																																																																																																																																																																																																																															
	Algebra																																																																																																																																																																																																																																																																																																																																																																																																																																																																																																																																																																																																																																		
	Geometry																	Measurement																																																																																																																																																																																																																																																																																																																																																																																																																																																																																																																																																																																																																	
	Measurement																																																																																																																																																																																																																																																																																																																																																																																																																																																																																																																																																																																																																																		
Think SMALL in a Big Way																	Comet Cratering																	Mysterious Seas and Skies																	Comet Basics																	Cookin' Up a Comet																	Incredible Edible Comet																	Famous Comets																	Comet Origins and Travels																	Voyage of Discovery																	Elliptical Orbits																	Rendezvous with Wild 2 Comet																	Feedback Loop																	Navigation Simulation																	Spacecraft Design & Testing																	Candy Model Spacecraft																	Egg Drop Sample Return																	Technology for Studying Comets																	Aerogel Clay Collector																	Paint by the Numbers																																																																																																																																																																																																																																																																																																																	
Comet Cratering																	Mysterious Seas and Skies																	Comet Basics																	Cookin' Up a Comet																	Incredible Edible Comet																	Famous Comets																	Comet Origins and Travels																	Voyage of Discovery																	Elliptical Orbits																	Rendezvous with Wild 2 Comet																	Feedback Loop																	Navigation Simulation																	Spacecraft Design & Testing																	Candy Model Spacecraft																	Egg Drop Sample Return																	Technology for Studying Comets																	Aerogel Clay Collector																	Paint by the Numbers																																																																																																																																																																																																																																																																																																																																		
Mysterious Seas and Skies																	Comet Basics																	Cookin' Up a Comet																	Incredible Edible Comet																	Famous Comets																	Comet Origins and Travels																	Voyage of Discovery																	Elliptical Orbits																	Rendezvous with Wild 2 Comet																	Feedback Loop																	Navigation Simulation																	Spacecraft Design & Testing																	Candy Model Spacecraft																	Egg Drop Sample Return																	Technology for Studying Comets																	Aerogel Clay Collector																	Paint by the Numbers																																																																																																																																																																																																																																																																																																																																																			
Comet Basics																	Cookin' Up a Comet																	Incredible Edible Comet																	Famous Comets																	Comet Origins and Travels																	Voyage of Discovery																	Elliptical Orbits																	Rendezvous with Wild 2 Comet																	Feedback Loop																	Navigation Simulation																	Spacecraft Design & Testing																	Candy Model Spacecraft																	Egg Drop Sample Return																	Technology for Studying Comets																	Aerogel Clay Collector																	Paint by the Numbers																																																																																																																																																																																																																																																																																																																																																																				
Cookin' Up a Comet																	Incredible Edible Comet																	Famous Comets																	Comet Origins and Travels																	Voyage of Discovery																	Elliptical Orbits																	Rendezvous with Wild 2 Comet																	Feedback Loop																	Navigation Simulation																	Spacecraft Design & Testing																	Candy Model Spacecraft																	Egg Drop Sample Return																	Technology for Studying Comets																	Aerogel Clay Collector																	Paint by the Numbers																																																																																																																																																																																																																																																																																																																																																																																					
Incredible Edible Comet																	Famous Comets																	Comet Origins and Travels																	Voyage of Discovery																	Elliptical Orbits																	Rendezvous with Wild 2 Comet																	Feedback Loop																	Navigation Simulation																	Spacecraft Design & Testing																	Candy Model Spacecraft																	Egg Drop Sample Return																	Technology for Studying Comets																	Aerogel Clay Collector																	Paint by the Numbers																																																																																																																																																																																																																																																																																																																																																																																																						
Famous Comets																	Comet Origins and Travels																	Voyage of Discovery																	Elliptical Orbits																	Rendezvous with Wild 2 Comet																	Feedback Loop																	Navigation Simulation																	Spacecraft Design & Testing																	Candy Model Spacecraft																	Egg Drop Sample Return																	Technology for Studying Comets																	Aerogel Clay Collector																	Paint by the Numbers																																																																																																																																																																																																																																																																																																																																																																																																																							
Comet Origins and Travels																	Voyage of Discovery																	Elliptical Orbits																	Rendezvous with Wild 2 Comet																	Feedback Loop																	Navigation Simulation																	Spacecraft Design & Testing																	Candy Model Spacecraft																	Egg Drop Sample Return																	Technology for Studying Comets																	Aerogel Clay Collector																	Paint by the Numbers																																																																																																																																																																																																																																																																																																																																																																																																																																								
Voyage of Discovery																	Elliptical Orbits																	Rendezvous with Wild 2 Comet																	Feedback Loop																	Navigation Simulation																	Spacecraft Design & Testing																	Candy Model Spacecraft																	Egg Drop Sample Return																	Technology for Studying Comets																	Aerogel Clay Collector																	Paint by the Numbers																																																																																																																																																																																																																																																																																																																																																																																																																																																									
Elliptical Orbits																	Rendezvous with Wild 2 Comet																	Feedback Loop																	Navigation Simulation																	Spacecraft Design & Testing																	Candy Model Spacecraft																	Egg Drop Sample Return																	Technology for Studying Comets																	Aerogel Clay Collector																	Paint by the Numbers																																																																																																																																																																																																																																																																																																																																																																																																																																																																										
Rendezvous with Wild 2 Comet																	Feedback Loop																	Navigation Simulation																	Spacecraft Design & Testing																	Candy Model Spacecraft																	Egg Drop Sample Return																	Technology for Studying Comets																	Aerogel Clay Collector																	Paint by the Numbers																																																																																																																																																																																																																																																																																																																																																																																																																																																																																											
Feedback Loop																	Navigation Simulation																	Spacecraft Design & Testing																	Candy Model Spacecraft																	Egg Drop Sample Return																	Technology for Studying Comets																	Aerogel Clay Collector																	Paint by the Numbers																																																																																																																																																																																																																																																																																																																																																																																																																																																																																																												
Navigation Simulation																	Spacecraft Design & Testing																	Candy Model Spacecraft																	Egg Drop Sample Return																	Technology for Studying Comets																	Aerogel Clay Collector																	Paint by the Numbers																																																																																																																																																																																																																																																																																																																																																																																																																																																																																																																													
Spacecraft Design & Testing																	Candy Model Spacecraft																	Egg Drop Sample Return																	Technology for Studying Comets																	Aerogel Clay Collector																	Paint by the Numbers																																																																																																																																																																																																																																																																																																																																																																																																																																																																																																																																														
Candy Model Spacecraft																	Egg Drop Sample Return																	Technology for Studying Comets																	Aerogel Clay Collector																	Paint by the Numbers																																																																																																																																																																																																																																																																																																																																																																																																																																																																																																																																																															
Egg Drop Sample Return																	Technology for Studying Comets																	Aerogel Clay Collector																	Paint by the Numbers																																																																																																																																																																																																																																																																																																																																																																																																																																																																																																																																																																																
Technology for Studying Comets																	Aerogel Clay Collector																	Paint by the Numbers																																																																																																																																																																																																																																																																																																																																																																																																																																																																																																																																																																																																	
Aerogel Clay Collector																	Paint by the Numbers																																																																																																																																																																																																																																																																																																																																																																																																																																																																																																																																																																																																																		
Paint by the Numbers																																																																																																																																																																																																																																																																																																																																																																																																																																																																																																																																																																																																																																			

Think SMALL in a Big Way

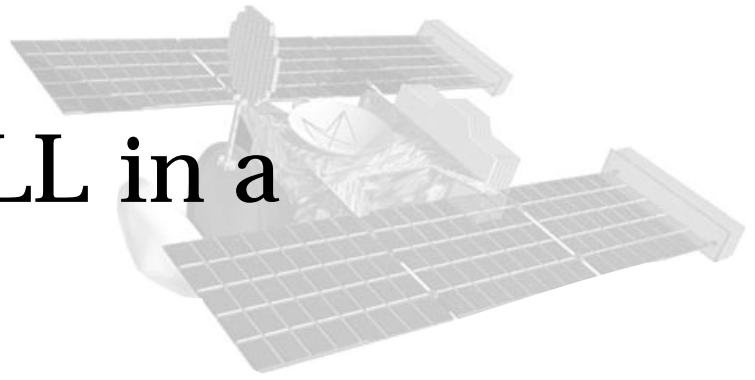

This section contains the basics on the small bodies of the Solar System, their significance, and reasons you, the teacher, should find small bodies worth teaching in the classroom. You will also find overviews of upcoming missions. The activity in this section deals with a few of the reasons small bodies are important:

- ◆ **Comet Cratering** - Models crater formation. Impacts on Earth can create craters and affect ecosystems (possibly including the extinction of the dinosaurs).

Comet Wild 2 was chosen for the STARDUST mission because it is “pristine.” The fewer times a comet has traveled near the Sun, the closer it is to its original state back when the Solar System formed. Each time a comet travels through the inner Solar System, it loses more of its original gases and dust as it passes by the Sun. Comet Wild 2 will only have made five orbits around the Sun by the time the STARDUST spacecraft reaches it, hence its “pristine” condition.

Think SMALL in a Big Way

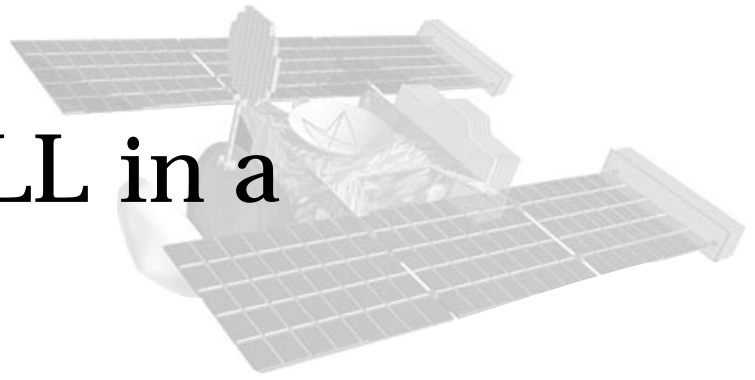

Our Solar System may have a star, nine planets, and a few dozen moons, but often overlooked are the billions of small bodies that orbit the Sun. Comets, asteroids, and meteoroids, ranging in size from a grain of sand to a large state, have recently begun to receive a lot of attention. What they lack in mass they make up for in style: meteoroids can produce spectacular meteor showers, asteroid impacts can shape the topography of planets, and one of nature's most breathtaking phenomena can be a comet sporting a long, elegant tail.

Why Study Small Bodies?

Although generally overlooked, small bodies make big impacts in the Solar System and can leave a lasting impression on students as well. There are a number of compelling reasons why scientists study small bodies:

- ◆ Because they are among the oldest objects in the Solar System, small bodies can help us understand how the Solar System was formed and evolved.
- ◆ Impacts from comets may have deposited material that contributed to the formation of the oceans and atmospheres on some planets, including Earth.
- ◆ Some people believe that life may have its roots in the chemical compounds that are found in comets.
- ◆ Small bodies have left craters on all of the terrestrial planets and moons, and the Earth is no exception. There are dozens of identifiable craters on our planet, some as large as 140 kilometers across! Hundreds of objects must have hit the planet in the past, but erosion has obliterated all but the largest or most recent craters.
- ◆ Impacts can affect climate and ecosystems on a global scale. Some scientists theorize that an impact by an asteroid or comet over 10 kilometers in diameter was responsible for the extinction of the dinosaurs. Astronomers today track near-Earth asteroids as they trek through the Solar System, and are constantly discovering new ones. Many scientists believe that Earth will be hit by a small body again sometime in the future.

“SMALL Bodies’ Big Impact”



Notes

Asteroids

Small bodies of the Solar System are divided into three categories: asteroids, comets, and meteoroids. Asteroids are metallic, rocky bodies that orbit the Sun and range in size from 1,000 kilometers in diameter down to the size of pebbles. Asteroids are thought to be material left over from the formation of the Solar System that was prevented by Jupiter’s strong gravity from forming a planet-sized body. It is estimated that the total mass of all asteroids would comprise a body approximately 1,500 kilometers in diameter (less than half the size of the Moon). Most asteroids are found in the asteroid belt, an area between the orbits of Mars and Jupiter. Astronomers believe that there are over 100,000 objects in the belt. However, asteroids exist in locations throughout the Solar System. Trojan asteroids orbit 60 degrees ahead of and behind Jupiter, held in place by the gravitational tugs of the Sun and the planet. Asteroids whose orbits bring them within the orbit of Earth are called near-Earth asteroids (NEAs). The Apollo asteroids are examples of NEAs. Asteroids can be grouped into three categories: carbonaceous, which comprise 75% of known asteroids and inhabit the main belt’s outer region; silicaceous, which dominate the inner asteroid belt and comprise 17% of known asteroids; and metallic, in the middle region.

Comets

Comets are only a few (1-20) kilometers in diameter and are made of ices and rock. They usually have orbits that are long and elliptical compared with most asteroids. Comets originate at the outer edges of the Solar System. When a comet is far away from the Sun (beyond the orbit of Jupiter), its *nucleus* (the solid part of the comet) remains frozen and changes very little. As it approaches the inner Solar System, however, the volatile ices of the nucleus begin to *sublimate*, or change directly from a solid to a gas. The gases and dust released from the comet form a *coma* around its nucleus, which can grow to become 100,000 kilometers in diameter and usually grows in size and brightness as the comet approaches the Sun. The Sun’s radiation pressure and solar wind accelerate materials away from the coma at differing velocities according to the size and mass of the materials. Thus, two tails are formed—one of dust and one of gas. A tail may extend to millions of kilometers from the head. Each time a comet approaches the Sun, it loses some of its volatiles; eventually becoming just another rocky mass in the Solar System.

Meteoroids

Meteoroids are different from comets and asteroids chiefly in size. They are very small, usually only a few centimeters to a few meters in diameter. Meteoroids are believed to be pieces of asteroids left over from collisions with other asteroids, as well as grains of dust ejected from comets. We are most familiar with meteoroids when they enter Earth’s atmosphere. The particles are heated by friction, creating a streak of light against the night sky. This phenomenon is known as a *meteor*. A *meteor shower* occurs when Earth passes through the leftover dust from the tail of a comet. During showers, the number of meteors witnessed can increase from just



a couple to over 50 an hour. If a piece of the original meteoroid survives its journey and reaches Earth, it is called a *meteorite*. Most meteorites are discovered long after they have hit Earth. A few are seen falling and are collected immediately. Some of the most successful meteorite collecting occurs in Antarctica, where shifting ice concentrates meteorites in certain areas and the dark rocks contrast well with the white terrain. Meteorites are difficult to classify, but the three broadest groupings are stony, stony iron, and iron. Chondrites, which are stony meteorites, are the most common and radiometric dating has placed them at the age of 4.55 billion years (approximately the age of the Solar System).



Upcoming Missions

The awe inspired by small bodies is infused in the scientific community as well. Scientists have recently recognized these small bodies as an important puzzle piece for understanding the formation and evolution of the Solar System. As a result, six spacecraft will rendezvous with at least ten different small bodies over the next several years:

- ◆ NEAR, launched in 1996, will perform the first scientific survey of near-Earth asteroids in the years 1997-1999.
- ◆ *Muses-C/Muses-CN*, to be launched in early 2002, will send a rover to explore and sample Asteroid 1989 ML and return fragments of the asteroid's surface for further detailed analysis.
- ◆ *Deep Space 1*, primarily a platform to test new instruments for future missions, will encounter Asteroid 1992 KD in 1999, and Comets Wilson-Barrington and Borrelly if the mission is extended.
- ◆ *Contour* (Comet Nucleus Tour) will assess comets for their diversity, encountering Comets Encke, SW3, and d'Arrest in 2003-2008.
- ◆ STARDUST, launched in February 1999, will rendezvous with Comet Wild 2 in 2004 and become the first spacecraft to sample cometary dust and return it to Earth for analysis.
- ◆ Rosetta is a cometary mission that will be launched in 2003 by Ariane 5. Rosetta will rendezvous with comet Wirtanen and orbit it, while taking scientific measurements.
- ◆ Deep Impact will send a 500 kilogram impactor to blast a crater into a comet nucleus, revealing the never-before-seen materials and structure of the interior of a comet.

What we learn about them is expected to reshape our understanding of how our Solar System-and perhaps even how life-formed.

STARDUST

STARDUST is the fourth of several flight missions in NASA's Discovery program. The goal of the Discovery program is to design small, less expensive spacecraft with specific scientific goals that can be built in 36 months or less. *Mars Pathfinder* and *Lunar Prospector* are examples of Discovery missions chosen in the past.





The spacecraft was launched in February 1999 on board an expendable launch vehicle and rendezvous with Comet Wild 2 in January 2004, coming within 150 kilometers (93 miles) of the comet's nucleus. The spacecraft will be the first ever to collect dust spewed from a comet and return it to Earth for detailed analysis. The comet samples are made up of ancient pre-solar interstellar grains and material that condensed in the solar nebula, a diffuse cloud of gas and dust from which the Sun and planets formed. A sample return capsule will reenter Earth's atmosphere and land on a dry lake bed in Utah in January, 2006. For more information on STARDUST, see the STARDUST Mission Fact Sheet.

Key STARDUST Dates	
1974	Comet Wild 2 orbit altered by Jupiter, bringing it into the inner Solar System in pristine condition
January 1978	Paul Wild discovers Comet Wild 2
1995	NASA selects STARDUST mission
February 1999	STARDUST Launch
January 2000 - May 2000	First Interstellar Dust Collection
January 2001	Earth flyby
July 2002 - December 2002	Second Interstellar Dust Collection
January 2004	Wild 2 Encounter
January 2006	Sample Return Capsule returns to Earth



Comet Cratering

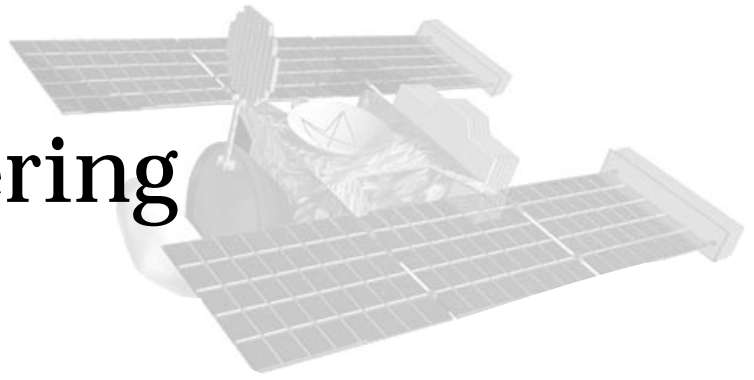

Overview

Students will discover what happens when impactors hit the surface of a planet using balls of different sizes, flour and cocoa. If a large enough comet impacted Earth, the result could affect ecosystems. Some scientists theorize that a large comet or asteroid impacted Earth millions of years ago, leading to the extinction of the dinosaurs.

Timeline

1 to 2 class periods

Objectives

- ◆ Create impact craters.
- ◆ Describe the relationship between the size of the crater and the size, speed, and distance of the impactor.
- ◆ Observe and record how light at various angles shadows craters and highlights relief.
- ◆ Estimate the age of a planetary surface.

Key Question

What can you learn by studying craters on a planetary surface?

Preparation

1. Read through the lesson and try out this activity yourself before doing it with students.
2. Make a transparency of the picture of the Barringer Meteor Crater on page 191.
3. You may want to put one careful student in charge of passing out the flour to each of the groups or prepare trays ahead of time. Demonstrate how to put a thin layer of the dark powder on top of the flour using a flour sifter.
4. Discuss types of surfaces and surface layers on Earth.



Materials

- Flour or mortar powder
- 1 cup of hot chocolate powder or cocoa
- A flour sifter
- A kitty litter box or pizza box lid
- Garbage bags
- 3 rulers
- Various sizes of balls (marbles, golf balls, etc.)
- 1.5 meters of string per team
- Scissors
- Chair
- Drop cloth or newspaper
- Safety goggles for each team member
- Overhead projector
- Transparency sheet with images of Barringer Crater and Mimas

Management

This activity is messy. Be sure to have floor coverings or make the craters outside. Students can measure the diameter of each ball by putting the ball between two rulers and measuring the distance between the rulers.

CAUTION: Students should wear safety goggles when making craters to prevent ejecta from getting into their eyes. Also students should be careful when standing on top of chairs.

When looking at the crater images, make sure students understand that crater floors sometimes look deeper than they really are because of the shadowing effects of various light sources on craters, which they will study in the second part of this lesson.

Procedure

1. Ask students what they know about comets. Find out why they think it is important to study comets. Write down their responses on the chalkboard. They might hit on reasons mentioned in Think SMALL in a Big Way on page 3. If not, lead them toward the question, "What would happen if a comet hit Earth?"

Depending on the size of the comet nucleus and a few other factors, the comet may never get through Earth's atmosphere, or it could impact and create a crater. A really big crater caused by a comet more than 10 kilometers in diameter is thought to possibly have led to the extinction of the dinosaurs.

2. Ask the class if they know how craters are formed. Tell them that they will find out by conducting an experiment.



3. Explain how students will work together in teams of four or five.
4. Coach and facilitate the activity, asking Reflection Questions throughout.
5. Have the reporter for each group explain and discuss the group's results.
6. Place the transparency of Barringer Crater and Mimas, a moon of Saturn, on the overhead projector. Keep Mimas covered with a piece of paper. Have students identify the parts of Barringer Crater.
7. Show Mimas. Have students explain what they think happened. Scientists speculate that whatever hit Mimas probably came close to disintegrating this moon.
8. Follow up with Reflection Questions.



Reflection Questions

1. Name several ways that simulating cratering in the classroom differs from real impacts.
2. What kinds of objects in the Solar System make craters?
3. Give three reasons why scientists use models.

NOTE: In addition to using models to study impact craters, scientists have also used real explosions. Early work on cratering included the examination of bomb craters, including some the size of the Meteor Crater, also known as the Barringer Meteor Crater. Scientists also use high-speed guns to make simulated craters, and they observe real craters to gain further insights.

4. What determines the size of a model crater?

NOTE: Again, remind students that it is the speed of the impactor, and not the distance, that is important in real cratering. Only in the classroom does distance have a noticeable effect on craters.

Worksheet Answer Key

Answers will vary depending on the size of the impactors chosen.

1. The surface is smooth, level, and uniform, with a dark layer over a light layer.
2. Answers will vary depending on ball sizes.
3. & 4. Chart data will vary; however, data should indicate that the larger the height, the larger the crater, and the larger the impactor, the larger the crater. The graph should reflect this trend.
5. The larger the impactor, the larger the crater.
6. The taller the height, the bigger the crater.
7. Answers will vary. For us, the craters were roughly 1.5 to 2 times as big as the impactor.
8. Answers will vary, but drawings should show a crater with all parts labeled.
9. When impactors slam into planets, they cause rock and dust from deeper layers of the planet's surface to mix with the top layer. The flour represents the deeper layers of the planet, and the cocoa represents the surface layer.



Crater-Making Procedure



Notes

Follow these steps to make craters.

1. Make sure the string is 1.5 meters in length.
2. Measure the diameter of each of your impactors.
3. Take team positions, with the dropper standing on the chair and the material specialist spotting the dropper.
4. Have the reporter check the height of the string and make sure the setup is correct.
5. Drop the first impactor from the first height.
6. Carefully remove the impactor and measure the crater's diameter.
7. Fill in the information in the chart on the worksheet.
8. Repeat procedure for the next height.
9. Repeat procedure for the next impactor.

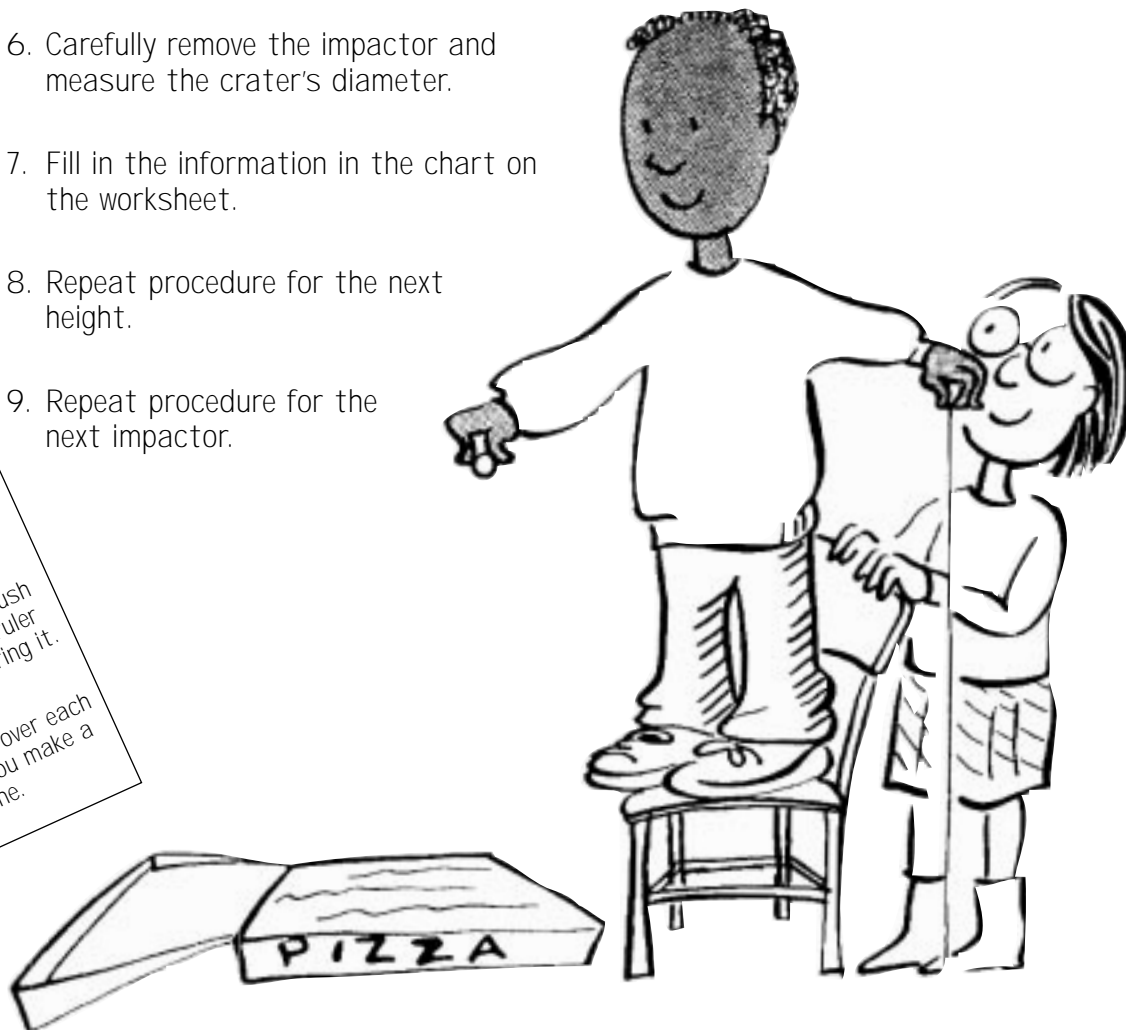
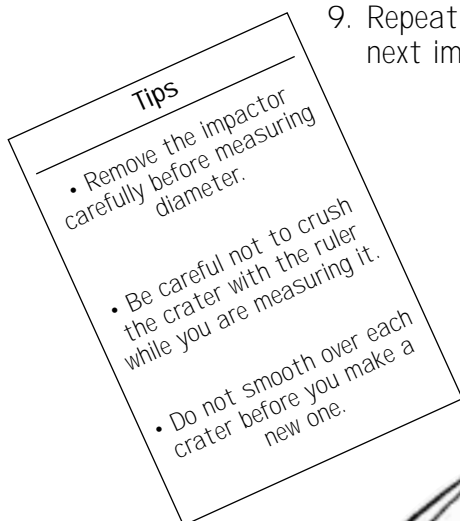

Comet Cratering Worksheet

Team _____

Date _____



Your Mission

Your mission is to make craters and examine them closely. What you learn about craters will help you tell a story about the life of the planets and moons in the images.

Roles

Decide which role each team member will assume:

- ◆ **Dropper:** drops impactors on the surface at the direction of the recorder.
- ◆ **Material Specialist:** is in charge of setting up materials and safety.
- ◆ **Measurer:** measures impactors and crater diameters.
- ◆ **Recorder:** writes down group answers and checks that calculations are done correctly.
- ◆ **Reporter:** closely examines impacts and speaks to the class for the team.

Setup

1. Lay down the drop cloth or newspaper.
2. Place the tray in the middle and fill the tray 3 inches (about 8 centimeters) high with flour.
3. Sprinkle a THIN layer of hot chocolate powder on top using a flour sifter.
4. Move a chair close to the tray.
5. Gather the impactors, string, and rulers.

Materials

- Flour or mortar powder
- 1 cup (8 ounces) of hot chocolate powder or cocoa
- A flour sifter
- A kitty litter box or pizza box lid
- Garbage bags
- 3 metric rulers
- Various sizes of balls (marbles, golf balls, etc.)
- 1.5 meters of string per team
- Scissors
- Chair
- Drop cloth or newspaper
- Safety goggles for each team member
- Overhead projector





Crater Making

1. Observe the setup of your testing field.
What does the surface look like?
2. Put two rulers on either side of an impactor and use the third ruler to measure the distance between them. This is the width or diameter of the impactor. Measure the diameter of all three impactors.

Ball 1 is _____ cm. Ball 2 is _____ cm. Ball 3 is _____ cm.

3. You will now make craters by following the directions on the Crater Making

	Height		Crater Diameter
Ball 1 diameter _____ cm	1st try	30 cm	_____
	2nd try	1.5 meters	_____
Ball 2 diameter _____ cm	1st try	30 cm	_____
	2nd try	1.5 meters	_____
Ball 3 diameter _____ cm	1st try	30 cm	_____
	2nd try	1.5 meters	_____

Procedure Sheet.



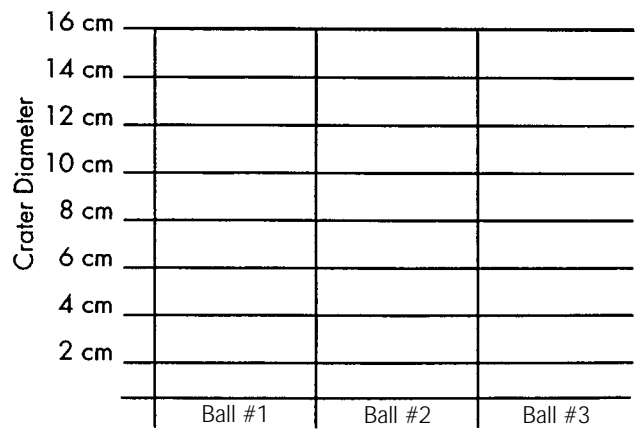
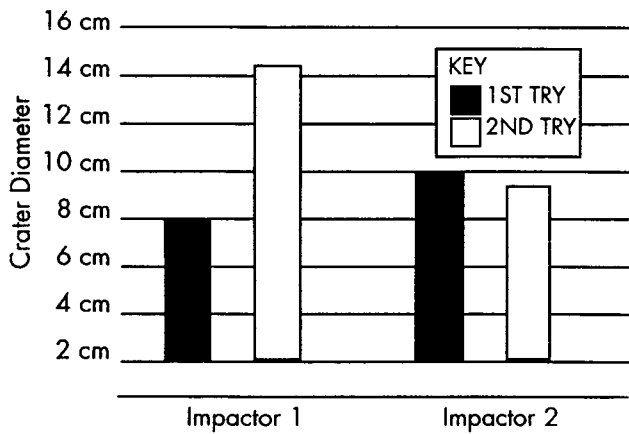

- Graph the results on a bar graph, following this example:
- How did the size of the impactor change the size of the crater?

- How did different heights change the size of the crater?

- Pick two different craters. How much bigger is the crater than the impactor?

$$\frac{\text{Impactor Size}}{\text{Crater Size}} = \underline{\hspace{2cm}} = \underline{\hspace{2cm}}$$

$$\frac{\text{Impactor Size}}{\text{Crater Size}} = \underline{\hspace{2cm}} = \underline{\hspace{2cm}}$$

- Pick the best crater in your tray. Draw what it looks like and label the parts.



- Look at your best crater. Notice the mixture of flour and cocoa. What does this mixture tell us about what craters do to the surfaces of planets?

Comet Basics

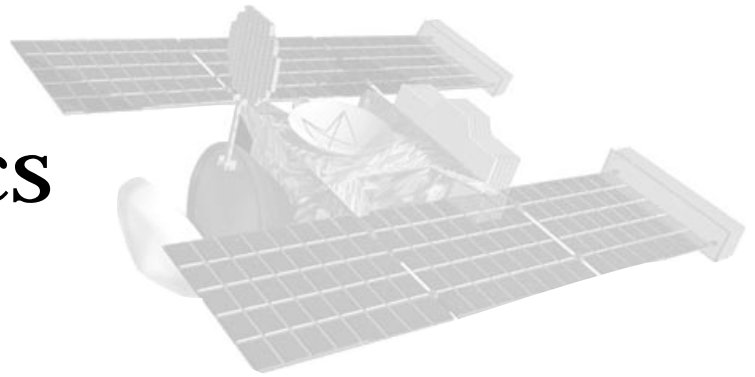

Sir Edmund Halley began our present day understanding of comets in 1705. He deduced that comets are actually objects within the Solar System and that one comet in particular kept coming back every 76 years. He predicted this comet's return and in 1758 (12 years after his death), his prediction came true, thus the name Halley's comet. The comet was last sighted in 1986 and will reappear in 2061.

Astronomers both professional and amateur have studied the skies for centuries, studying the passage of comets in the heavens, and searching the skies for new comets to bear the discoverer's name. Much of our present day knowledge about comets results from this research. In addition four spacecraft studied Comet Halley the last time it passed by Earth in 1986. The upcoming missions in the next ten years will lead to new insights and discoveries about these cosmic travelers. For example, STARDUST launched in 1999. The mission's primary goal is to collect comet dust and volatile samples during a planned close encounter with Comet Wild 2 in January of 2004. Comet Wild 2 was discovered by Paul Wild on January 6, 1978, during its first passage relatively near Earth (1.21 AU). (An astronomical unit, AU, is the distance between Earth and the Sun.) Although this comet is not considered to be a spectacular comet to view from Earth, since it will not travel closer to the Sun than Mars, it is of interest because it should still yield valuable information.

The activities on the next pages include basic information on comets. Interestingly enough, not all scientists agree that this information is "the truth." Perhaps it is safer to say, these are common scientific theories about comets. Scientists often interpret the same data in different manners, developing theories based on these interpretations. The upcoming missions will provide new information, possibly changing the "facts" and theories presented in these activities.

- ◆ **Cookin' Up a Comet** - Dramatically simulates a comet using dry ice and other ingredients.
- ◆ **Incredible Edible Comet** - Reviews the parts of a comet and serves as a sweet ice cream treat.
- ◆ **Famous Comets** - Uses the Internet to explore several famous comets.

Remember: Comets generally do not display comas or tails past Jupiter's orbit. The Sun's energy is not strong enough at this distance to turn the ices in the nucleus into gas and dust tails. Usually, the closer a comet travels to the Sun, the more ices sublime and the larger the coma and tail grow.

A great comet is one that can be seen with the naked eye, like Comet Hale-Bopp in 1997. Such a comet has a distinct tail. A person is lucky to see one or two such comets in a lifetime.

Cookin' Up a Comet



Notes

Overview

Students will learn the basic components of a comet and demonstrate how the comet's head and tail form by building a comet model.

Objective

- ◆ Compare the parts of the model to the parts of a comet.

Preparation

1. Purchase dry ice from ice companies or ice cream parlors the afternoon or evening prior to the demonstration. If possible, get the pellet form of dry ice. Be sure to purchase at least five pounds of dry ice. You will want to get enough extra for a test run at home the night before.
2. Store the dry ice in an ice chest. Place an inch or so of newspaper between the dry ice and the container to prevent the container from cracking.
3. Conduct this activity before using it in the classroom to get a feel for the correct amount of water to use.

CAUTION! Dry ice is -79°C (-110°F). Any more than brief exposure to the skin will cause “burns.” Everyone handling dry ice should wear heavy, rubber gloves! Be sure to discuss safety precautions with students when working with dry ice.

Timeline

1 class

Key Question

Of what are comets made?

Materials

- 5 lbs (~ 2 kg) dry ice pellets or block, chopped finely
- 3 cups of water
- A few drops of ammonia
- A handful of sand or ground charcoal
- A can of soda (cola)
- A large wide mixing bowl
- A large wooden or plastic spoon for stirring
- A hammer
- A large plastic tub
- Heavy, rubber gloves
- Protective eye goggles (1 pair per student)
- Cloth or paper towels
- Optional: Overhead projector, hair dryer, and plastic wrap



Management

This comet recipe is fun to do. It is also messy and one of the more scientifically accurate demonstrations in astronomy.

Procedure

1. Put on heavy gloves before using a hammer to crush the dry ice pellets or block in the large plastic tub to the consistency of snow. Everyone should wear protective eye goggles.
2. Pour 18 oz (2.5 cups) of water into the mixing bowl. Add a handful of sand, a little ammonia, and the cola, mixing as you pour.
3. Add 2.5 cups of dry ice to the mixture. Stir carefully. Vapor will form as you stir, and the mixture will get slushy. Keep stirring for a few seconds while it thickens.
4. Use the mixing spoon to clean the slush away from the sides of the bowl into the bottom. Reach in and pack the slush into a ball. Keep packing and forming until you have a ball that forms a big lump. Add water to help the ice stick together.
REMINDER: DO NOT HANDLE DRY ICE MIXTURE WITH BARE HANDS!
5. Sprinkle more sand over the comet. Pour some of the remaining water over the comet turning it as you do, so that a layer of water ice forms over the entire surface.
6. Observe the behavior of your miniature comet nucleus. Cool Comet Viewing Tip: So the whole class can watch the gas sublimating out of the comet, use an overhead projector. Be sure to protect the overhead projector by covering the glass with plastic wrap. **CAUTION!** Do not leave the comet on the projector long; the dry ice could damage it.
7. Blowing hard on the comet gives a sense of simulating a comet tail. One suggestion is to use a hair dryer set on a low setting.
8. Discuss the parts of a comet using the Comet Fact Sheet.

The ingredients used to “build” a comet represent our current understanding of the components found in actual comets: frozen water, frozen carbon dioxide and other frozen gases, dust and rock, and organic (carbon-based) substances.

Scientists have studied the spectrum of light coming from real comets’ comas and tails to determine the presence of these substances. The research carried out in the Comet Halley flyby missions and the ICE mission to Comet Giacobini-Zinner provided further evidence of comet composition.

As the comet in this experiment melts, you can see little jets of gas coming off the comet just like the observed “outgassing” of real comets, which can actually affect the movement of the comet. After further melting of the experimental comet, craters will begin to form, another characteristic of real comets.

9. Discuss the Reflection Questions as a class.





Reflection Questions

1. When you place the comet on the tray to observe it, what part of the comet does it represent?
2. Describe changes, if any, in the comet after 5 minutes have elapsed.
3. Use the hair dryer to represent the Sun and the solar wind. Set the dryer on the low setting and blow air on the comet. What part of the comet begins to form? What happens when you move the hair dryer closer to the comet?
4. What components of real comets are represented by each of the ingredients in your comet?

Answer Key

1. The nucleus or the head.
2. You could see melting, small gas jets escaping.
3. The tail; jets begin to point away from the blow dryer (Sun).
4. The ingredients are either actual components or handy analogous ones. Dry ice is frozen carbon dioxide. Water is water. Ammonia is ammonia. Cola provides the organic (carbon-based) molecules, and sand is rocky material.



The Incredible Edible Comet



Overview

Using ice cream and ice cream toppings, students explore the anatomy of a comet.

Objective

- ◆ To construct an edible model of a comet.
- ◆ To determine the anatomy of a comet.

Preparation

1. Collect the necessary ingredients as described in the materials list.
2. Prepare the model comets using the following procedure:
 - ◆ Mix the ice cream, crumbled candy bars, chopped nuts, and caramel syrup in a large bowl. Mix them together as thoroughly as possible.
 - ◆ Using the ice cream scoop, place single scoops of the ice cream mixture into a bowl, and freeze immediately.
 - ◆ Make one for each student, plus one for demonstration purposes.

Timeline

1 class

Key Question

What are the major parts of a comet?

Materials Needed

- Enough ice cream to provide one scoop for each student (representing the ice in a comet)
- Crumbled chocolate and butter-crunch candy bars (for the look of silicon)
- Finely chopped nuts (for the rock and dust within the comet nucleus)
- Caramel syrup (for the organic molecules, i.e., simple sugars)
- Whipped topping (for a tail)
- 1 liter ginger ale
- A mixing bowl
- A mixing spoon
- Ice cream scoop
- Individual bowls, one for each student, plus one for demonstration purposes
- Plastic spoons and napkins





Management

Due to the sugar content, you may prefer to save this activity for the last period of the day as a class-wide party.

Procedure

1. Distribute the Comet Fact Sheet. You may want to divide the class into groups at this time for easier distribution of the additional comet dishes later in the class period.
2. Unveil your comet nucleus for the class. Have students observe the nucleus and identify parts of the comet using the Comet Fact Sheet.
3. Using one bowl as a sample model, pour in a small amount of the ginger ale. The carbonation in the beverage represents carbon dioxide, one of many gases that have been observed escaping from comets. This outgassing causes the coma to appear.
4. Squirt whipped topping to represent the tail.
5. Ask the Reflection Questions to reinforce the parts of a comet. (See Materials Needed list.)
6. Distribute the additional comet model dishes and enjoy! You can let the students pour the ginger ale and whipped topping.

Reflection Questions

1. What does the ice cream represent? The crumbled candy bar? The ginger ale? The chopped nuts? The whipped cream?
2. Was there a dust tail in this comet? Why not? Did you observe a gas tail or coma?
3. How was the comet model like a real comet? How was it different?
4. How would this comet nucleus change as it entered the inner Solar System?



Famous Comets



Overview

Comets have played significant roles in both recent and ancient history. Usually considered bad omens by our ancestors, comets have more recently sparked interest due to their beauty, uniqueness, and sometimes their dramatic fates. This lesson has students research some of the more notable comets using the Internet and give a report on their findings.

Objective

- ◆ Research comets which are historically, scientifically, or otherwise significant.

Preparation

1. Copy enough Team Worksheets to provide one for each team.
2. Copy enough Comet Fact Sheets for each student.
3. Make arrangements for each team to have at least 1 hour of Internet access.

Management

Allow students plenty of time to research their comet. If necessary, encourage them to work on their project after-hours. Many libraries have Internet access.

Materials Needed

- Comet Research Team Worksheet for each team
- Comet Fact Sheet for each student
- Computers with access to the World Wide Web for each team
- Reference books/periodicals, etc.

Procedures

1. Review comets using the Comet Fact sheet. Discuss the anatomy, location, orbital paths, and composition of comets.
2. Assign students to cooperative groups and they will assign roles for students to study one of the following comets:
 - ◆ Comet Hale-Bopp
 - ◆ Comet Halley
 - ◆ Comet West
 - ◆ Comet Shoemaker-Levy 9
 - ◆ Comet Tempel-Tuttle
 - ◆ Comet Encke
 - ◆ Comet Wild 2

Timeline

- 1 class: Overview comet parts and assign teams.
- 2-3 class: Research famous comets and write a creative narrative.
- 1 class: Share stories and ask Reflection Questions.

Key Question

What roles have famous comets played in history?





3. Using the given Internet addresses and reference materials, have students answer the questions on the Team Worksheets.
4. Based on the information in the Comet Fact Sheet or from what they gathered, have the teams write a creative narrative about their comet using the writing prompts.
5. Have the team reporter share their story with the rest of the class (suggest a broadcast format).
6. Conclude the entire lesson with Reflection Questions.

Reflection Questions

1. What do comets have in common? How are comets different?
2. Do you think that a comet may hit a planet sometime in the future? Why or why not?
3. Does a comet's tail ever point towards the Sun? Why not?
4. Do you think that we see a lot of the Solar System's comets, or only a few? Why can't we see the other ones?

Answer Key

Worksheet answers will vary because each team has a different comet. Here are the basics:

Comet Hale-Bopp

period = 4,000 years

Hale-Bopp was an exceptionally bright comet that appeared in 1997.

Comet Halley

period = 76.03 years

Named for the man who first predicted the comet's return, Halley has appeared in numerous historical records as far back as 239 B.C.

Comet West

period = no longer applicable

A spectacular comet that appeared in 1976. When West approached perihelion, however, it broke into several pieces.

Comet Shoemaker-Levy 9

period = no longer applicable

Comet Shoemaker-Levy 9 gained notoriety when it slammed into Jupiter during July 1994.

Comet Tempel-Tuttle

period = 32.92 years

The leftover remnants of this comet's tail are responsible for the Leonid meteor shower that occurs annually.

Comet Encke

period = 3.3 years

This comet has the shortest known orbital period. It will also be investigated by the spacecraft *Contour*.

Comet Wild 2

period = 6.17 years

This short-period comet will be the subject of investigation by STARDUST.



Comet Research Team Worksheet



Name _____ Date _____

Team Roles

Decide which team member will perform each of the following roles:

Recorder: Records the results of the team's research.

Computer Operator: Uses the computer to navigate the Internet and print out any essential materials.

Literary Supervisor: Records team's input for the story.

Reporter: Presents the team's story to the rest of the class.

Steps

Name of your team's comet: _____

This activity has two parts. In the first part you will research the significance of a specific comet. In the second part you will write a story based on the facts surrounding your comet.

Using the Internet, answer the questions on the next page. Have the recorder write down what the team learns. It may help to use the following websites:

STARDUST Home Page

<http://stardust.jpl.nasa.gov>

Comets and Meteor Showers

<http://medicine.wustl.edu/~kronkg/index.html>

Comets and Asteroids at National Space Science Data Collection

<http://nssdc.gsfc.nasa.gov/planetary/planets/asteroidpage.html>

Comet Observation Home Page

<http://encke.jpl.nasa.gov/>

Challenger Center for Space Science Education Comet Links

<http://www.challenger.org/cometl.html>





1. What makes this comet unique?

2. How long is this comet's period?

3. What major events in history have happened when the comet has appeared?

4. How did this comet change the way astronomers think about comets or the Solar System?

5. Who discovered the comet? What country was the discoverer from? Was the discoverer a professional or amateur astronomer?

6. Print out a picture of the comet. Label its coma, gas tail, dust tail, and nucleus (if visible).

7. What was the most recent great comet?

8. What comets will appear in the night sky over the next three years?



Writing Prompts

Use the following writing prompts to help your team write a two-page story about your comet. Have the Literary Supervisor write the story as the rest of the team provides ideas and suggestions. Base your story on actual facts and science concepts.

- ◆ Imagine you are a reporter writing a headline story about sighting this comet.
- ◆ Imagine that you belong to another culture in another century when your comet appears. Describe what you see, what you think it is, and how you feel.
- ◆ Imagine you are an amateur astronomer watching the night sky when you think you discover a comet. How do you feel? Who do you tell?
- ◆ Imagine you are the comet. Talk about where you would travel during your entire orbit.
- ◆ Think of your own story!

Illustrate your story with the photo you printed of your comet. Make sure that its parts are labeled.



Comet Origins and Travels

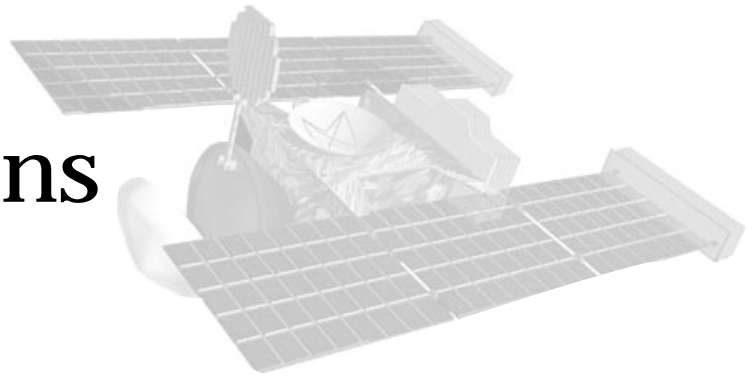

When comets are in the outer Solar System, beyond Neptune's and Pluto's orbit, they are small, dark, and so distant that detecting them is difficult. Still astronomers speculate that comets originate in a theoretical region called the Kuiper Belt and the Oort Cloud. Short-term comets, those with orbital periods less than 200 years, are said to originate in the Kuiper Belt. Those comets with periods greater than 200 years, and possibly thousands of years, are said to originate from the Oort Cloud. This section examines the origin of comets and characterizes their elliptical orbit through the Solar System.

- ◆ **Voyage of Discovery** - Walks students through a scale model of the Solar System over a 600 meter distance, beyond which comets originate.
- ◆ **Elliptical Orbits** - Draws an elliptical orbit using simple tools. Knowing a comet's elliptical orbit lets scientists predict where a comet will be at a given point in time, unless it gets pulled from its orbit by a giant gas planet.

Periodic Comet Wild 2 is new to the inner solar system. Before 1974, the comet was no closer to the Sun than Jupiter's orbit. When Wild 2 flew by Jupiter in 1974, the massive planet's gravitational force changed the comet's orbit; because of that it now travels closer to the Sun, between Jupiter and Earth.

By the time STARDUST encounters the comet, Wild 2 will have made only five trips around the Sun. By contrast, Comet Halley has passed the Sun more than 100 times. Since Wild 2 has passed by the Sun only a few times, it still has most of its dust and gases--we call that "pristine." This is important because comets are made up of material left over from the solar nebula after the planets were formed. Unlike the planets, most comets have not changed very much since the formation of the solar system. Therefore, comets hold the key to understanding the early development of the solar system. Wild 2 should contain much of this ancient material, making it an ideal choice for study.

STARDUST will fly close to Wild 2 and, for the first time ever, bring back material from a comet. This material will be collected from the coma and brought back to Earth to be analyzed. By analyzing this material, scientists may obtain clues to the formation of Earth, the solar system and perhaps even clues to the formation of other planetary systems.

Voyage of Discovery



Overview

This activity has two parts: Exploring Planet Sizes and Walking Planet Distances. In the first part students find objects (food and candy) to match the sizes of the planets for a Solar System model on the one ten-billionth scale. The second part of the activity takes the students outside to walk the distances between the planets over a 600-meter area. Comet Wild 2 orbits between the orbits of Mars and Jupiter once every 6.17 years. Most comets originate beyond the orbits of Neptune and Pluto. This activity gives students the opportunity to observe the change in orbit of Comet Wild 2. Previously, its orbit lay between Jupiter and a point near Uranus, but after 1974 it changed to its current orbit between the orbits of Mars and Jupiter.

Timeline

- 1 class for Part 1
- 1 class for Part 2

Key Question

How big is the Solar System if you could shrink it to one ten-billionth of its actual size?

This activity is based on Challenger Center's Voyages Across the Nation, a partnership between Challenger Center, the Smithsonian Institution, and NASA. This educational initiative is dedicated to fostering a deeper understanding of Earth's place in the Solar System, and the Sun's place among the stars. At the heart of Voyages Across the Nation are permanent outdoor exhibitions that depict the sizes and distances between the planets at one ten-billionth (1/10,000,000,000) the Solar System's actual size. The exhibitions' pedestals may display NASA color photographs, touchable model planets and moons, and encourage comparisons to Earth. The educational partners hope to place these exhibitions in communities around the nation.

Objectives

- ◆ Demonstrate the size of the Sun and the bodies of the Solar System on the ten-billionth scale.
- ◆ Construct and walk the distances between the bodies of the Solar System on the ten-billionth scale.

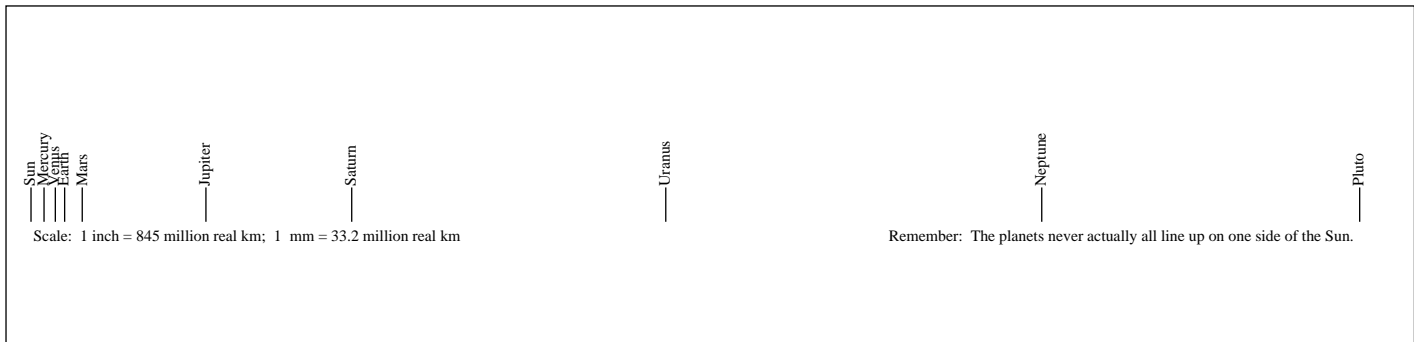

NOTE: The planets all move at different speeds in their orbits around the Sun. They do not really appear in a straight line. Make sure students understand this concept.



Preparation

PART 1: EXPLORING PLANET SIZES

1. Gather materials needed.
2. Make copies of the Student Worksheets.
3. Do NOT hand out Model Planet Cards until teams finish the first Student Worksheet.
4. Prepare a master set of Model Planet Cards using the correct foods to use in Part II.

PART 2: WALKING PLANET DISTANCES

1. Find an area outside to walk 600 paces (600 meters or 0.4 mile) in a more or less straight line. Walk the distances to the planets yourself. This is important!
2. If the ground is soft, use pins to fasten the model planet cards; otherwise, use tape. If possible, get ten helium balloons and use these on the walk instead of the cards. You can see the balloons at a distance. Flags made of plexiglass on plywood stakes can also be used and they are reusable.

Materials Needed

PART 1

- Balloon (for the model Sun)
- Metric ruler
- Miniature marshmallows
- Poppy seeds
- Mustard seeds
- Circle-shaped cereal
- Popcorn kernels
- Dried peas
- 1-cent gum balls
- Black pepper
- Glue
- Model Planet Cards

PART 2

- Voyage of Discovery Worksheet
- Pins or masking tape (ask your teacher)
- Pencil
- Hard writing surface (to take outside)





3. Students will need to bring Part 2 of their worksheets, pins or tape, a pencil and a hard writing surface on the walk.

Management

This activity has two parts, each of which can be completed in one class period.

Part 1 looks at the sizes of the planets and takes place in the classroom. Students predict the size of Earth and Jupiter and find foods (like cereal, gum balls, marshmallows, etc.) that are about the size of each planet. The foods are listed in the Materials List on the Student Worksheet. These choices are only suggestions; other foods will also work as models. Use whatever is convenient.

Part 2 requires the class to go outside to walk the distances between the planets. If possible, find a long stretch of land to walk the 600 meters. If not, a track will work, but it is not as dynamic.

Walking the inner planets takes little time. Walking to Jupiter and each of the other outer planets takes much longer. Encourage a different team of students to be in charge of counting the paces out loud for one planet. Marking the place of each planet with a helium balloon is a good idea; you can see the balloons at a distance.

Procedure

PART 1: EXPLORING PLANET SIZES

1. Read through the Student Worksheet. This is where you will find the Materials List.
2. Discuss Earth, the Solar System, and why we need models to help study them.
 - ◆ Here is a riddle you can use:
What is the biggest thing you have ever touched? Depending on where you can touch it, it can be wet or dry, hot or cold, and everybody you know has touched it, too. What is it?
 - ◆ Earth is the biggest thing we have ever touched, but Earth is not the biggest planet in the Solar System. We cannot just look up in the sky and see the whole Solar System and how it works. It is too big, and the planets are too far away.
 - ◆ Models let us take objects that are vast-bigger than we can understand-and bring them down to a size we can understand.
3. Show students the model Sun-the balloon blown up to 14 cm (5.5 in). Based on the size of the model Sun, students will work in teams of four or five to answer questions 1-5. These questions reveal what students think about planet sizes.
4. Discuss students' predictions and give them the answers.
5. Pass out the Model Planet Cards. Direct each team to glue the cereal, marshmallows, etc., to match the size of each planet.
6. Go around the room, having each team's reporter give reasons why they picked each object to use for a given planet.



7. Ask students to predict what size a comet is on this scale. Keep in mind that while comet sizes differ, they are generally the size of a city. So, on this scale a comet that does not have a tail is microscopic. Comets have the unique distinction of being one of the smallest and largest objects in the solar system. A comet's tail can at its longest extend the distance between the Sun and Earth. Students will find out how long this distance is during the second part of the activity.
8. Using the correct foods, prepare a master set of Model Planet Cards to use in Part 2. Let the glue dry and cut up cards for the walk. You may want to attach the cards to helium balloons for the walk to make the planets easy to see at a distance.



PART 2: WALKING PLANET DISTANCES

1. Before taking the class outside, introduce the “pace” as the “ruler” for this model. A pace is two steps—one with each foot. One pace is about 1 meter. You can use a meter stick for reference and for practice “pacing.”
2. Have each team predict how far away the Earth card should be from the model Sun, using paces or meters.
3. Take your class outside to walk the model length of the Solar System. Take the cut-up master Model Planet Cards you made in Part 1.
4. For each planet, choose a team of students to be the official “pace setter” and “planet bearer” to fasten the planet at the correct distance.
5. Fasten the Sun to the ground (or tie a helium balloon to a nearby object). Tell the class the number of paces to Mercury, and tell students to complete the chart on their worksheets. “Walk” to Mercury, fasten the Mercury Planet Card to the ground, and repeat the process for all planets.
6. Ask the students questions from the Reflection Questions while walking the distances between the outer planets. These distances are large, so students’ attention may wander. In this model, a spacecraft would move an average of 3 cm (1 in) every 5 hours.

NOTE: Be sure to point out the asteroid belt between Mars and Jupiter. Neptune was the most distant planet in the Solar System from 1979 until 1999 when Pluto passed outside of Neptune’s orbit. Also be sure to tell students, once they reach Pluto, that most comets originate even farther away beyond the orbits of Neptune and Pluto.

7. Back in the classroom, conclude the activity with Reflection Questions.

NOTE: Be sure to remind students that the planets do not really form a straight line. They all travel around the Sun at different speeds, so they are constantly changing positions.





Reflection Questions

1. Did the position of Mercury surprise you?
2. How would the real Sun look from the real Mars compared to how we see the Sun from Earth?
3. Compare the sizes of the inner and outer planets.
4. How have we learned so much about the planets?
5. How fast do you think a spacecraft would travel on this model?
6. How do distances challenge spacecraft?
7. Were your predictions for the size of Earth and Jupiter right?
8. Were your predictions for the distance of the model Earth right?
9. What are some of the differences between the sizes of the inner and outer planets?
10. Why is Pluto so difficult to classify as either an inner or an outer planet?
11. What did you learn about the distances of the planets in the Solar System?

Worksheet Answer Key

PART 1

1. D
2. Jupiter
3. B
4. Mars, Mercury, and Pluto
5. Jupiter, Uranus, Saturn, and Neptune
6. These are suggestions for foods to use on the Model Planet Cards.
Mercury and Mars: poppy seeds
Jupiter and Saturn: miniature marshmallows, 1-cent gum balls, circular-shaped cereal
Pluto: a piece of black pepper
Venus and Earth: mustard seeds
Uranus and Neptune: popcorn seeds or dried peas

PART 2

1. Answers will vary.

2.	Walking From:	Paces (or meters) Between Models	Total Distance From Model Sun to Each Planet
	Sun to Mercury	6 meters	6 meters
	Mercury to Venus	5 meters	11 meters
	Venus to Earth	4 meters	15 meters
	Earth to Mars	8 meters	23 meters
	Mars to Jupiter	55 meters	78 meters
	Jupiter to Saturn	65 meters	143 meters
	Saturn to Uranus	144 meters	287 meters
	Uranus to Neptune	163 meters	450 meters
	Neptune to Pluto	142 meters	592 meters

3. Answers will vary.
4. Answers will vary.



Voyage of Discovery Worksheet



PART 1: EXPLORING THE PLANET SIZES

Blow up a balloon to 14 centimeters in diameter. This balloon is a model Sun that is approximately one ten-billionth ($1/10,000,000,000$) the size of the real Sun. The questions below show planets that use the balloon as the scale model for the Sun.

Your Mission

You are scientists investigating the distances between the planets from your home planet, Earth. To do this, you must reduce the Solar System to a walkable distance, one ten-billionth of the size of the actual Solar System.

Roles

Decide which role each team member will assume:

- ◆ Leader: keeps the group on task.
- ◆ Materials Specialist: collects items on the Materials List.
- ◆ Recorder: writes down group answers.
- ◆ Reporter: speaks for the team.

Steps

1. Predict which circle below you think represents the model Earth, if the balloon is the model Sun.

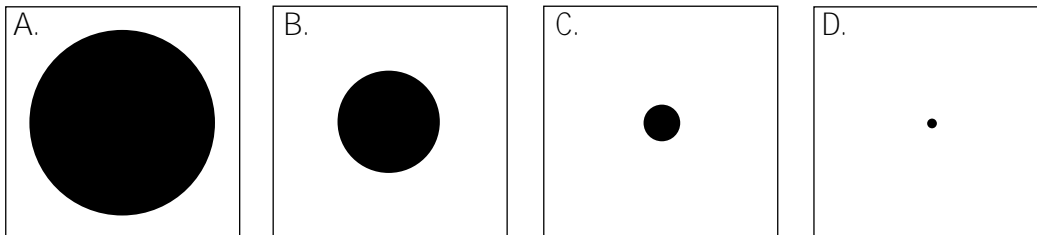

2. Which planet is the biggest? Circle one.

Earth Jupiter Mars Mercury Neptune
Pluto Saturn Uranus Venus





3. Which circle below do you think represents the biggest planet?

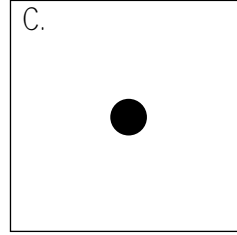
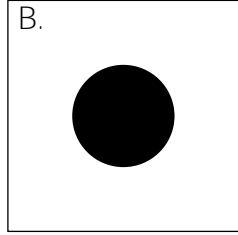
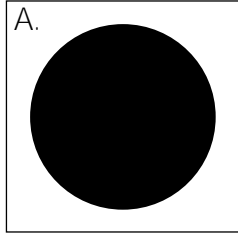

4. Look at the Model Planet Cards. What are the three smallest planets?

1. _____
2. _____
3. _____









5. What are the four largest planets? These are called the gas giants.

1. _____
2. _____
3. _____
4. _____

6. Using the items on the Materials List, match them to the size of the planets on the cards, and glue them to the right card.

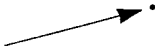

Model Planet Cards

 <p>Mercury</p>	
 <p>Jupiter</p>	 <p>Saturn</p>
 <p>Earth</p>	 <p>Venus</p>
 <p>Pluto</p>	 <p>Mars</p>
 <p>Uranus</p>	 <p>Neptune</p>



Part 2: Walking Model Planet Distances

1. Find your model Sun and model Earth. How far do you think the model Earth should be from the model Sun? State your answer in meters.

_____ meters

2. Walk the distances between the planets outside with your class and complete the chart below with your teacher's help.

MODEL DISTANCES CHART

Walking From:

**Paces (or meters)
Between Models**

**Total Distance From
Model Sun to Each Planet**

Sun to Mercury		
Mercury to Venus		
Venus to Earth		
Earth to Mars		
Mars to Jupiter		
Jupiter to Saturn		
Saturn to Uranus		
Uranus to Neptune		
Neptune to Pluto		

Warning: The planets never actually all line up to one side of the Sun. They orbit the Sun on different paths at different speeds. Some planets orbit in different planes.

3. What were you surprised to learn about the size of the planets?

4. What were you surprised to learn about the distances between the planets?



Elliptical Orbits



Overview

Almost everything orbiting the Sun travels in an ellipse. This activity has students explore ellipses of varying eccentricity using string, pushpins, and a pencil.

Objective

- ◆ Create ellipses and use them as models of real orbits.

Activity Preparation

1. Collect corrugated cardboard boxes and cut out pieces approximately 25 cm X 30 cm.
2. Gather materials.
3. Review the concept of orbits and ellipses with students.
4. Make copies of student worksheets.

Management

Caution: Pushpins are sharp. Monitor their use closely and check to make sure that none have fallen to the floor before moving on to the next lesson.

Timeline

1 to 2 classes

Key Question

How do comets travel through the Solar System?

Materials Needed

For each student:

- A copy of the Student Worksheet
- 25 cm x 30 cm piece of cardboard
- Three blank, white sheets of 8.5" x 11" (about 21 cm x 27 cm) paper
- Pencil
- 20-cm-long piece of string
- Two push pins
- Metric ruler
- Tape





Procedures

1. Review the student procedures, as listed on the student worksheet.
2. Collect corrugated cardboard boxes and cut out pieces approximately 25 cm x 30 cm.
3. Gather the materials listed in the materials section.
4. Make copies of the Student Worksheet.

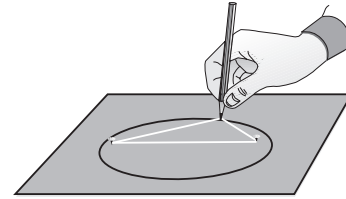

Ellipse/Eccentric Orbits

All bodies orbiting the Sun travel in paths called ellipses. An ellipse looks like a stretched out circle. The amount an ellipse is stretched out is called its eccentricity. The orbits of most of the planets are shaped like circles that have been stretched out just a little. In other words, their eccentricity is low.

The planet Pluto has an orbit that is more stretched out than the orbits of the other planets. No one really knows why the planet Pluto's orbit is more eccentric than those of the others, but there are many theories. Some scientists believe that Pluto was once a moon of the planet Neptune and was ripped from its orbit by a passing comet.

Comets, which have highly eccentric orbits, may take hundreds, even thousands, of years to complete one orbit around the Sun. As they near the Sun, they speed up; they slow down as they move to the outer regions of the Solar System beyond the planets. The elliptical orbit of a comet resembles the shape of a cigar.

The Sun's mass provides the gravitational force which pulls objects around in their elliptical paths. Johannes Kepler, a scientist who lived in the early 1600s in Germany, discovered the relationship between the speed of a planet and its distance from the Sun. He noticed that as an object gets closer to the massive Sun, it is pulled around faster. Also, the farther away a planet is from the Sun, the more slowly it moves around in its orbit. For example, Mercury, the planet closest to the Sun, orbits in just under 88 days, while Neptune and Pluto are the farthest planets from the Sun and take over 100 years!

5. Before starting this lesson, students must have a solid understanding of the properties of ellipses and how they relate to comets. Review the information in the Background section with the students. Explain that all objects in the Solar System travel around the Sun in an ellipse. If possible, show a diagram of the orbits of planets, asteroids, and comets as an example.
6. Choose student helpers to assist you in distributing the materials for the lesson.
7. Briefly demonstrate how to use the pencil, string, and thumbtacks to draw an ellipse. As a class, note the foci and major and minor axes of the ellipse.



Reflection Questions

1. If the Sun is at one of the foci of an orbital ellipse, is there anything at the other focus?
2. What do you think an orbit with an eccentricity of 0.95 would look like? Of 0.25?

Answer Key

1. Focal points
2. The eccentricity of the circle is 0. The eccentricity of ellipse 1 should be a number between 0 and 1. Answers will vary slightly because of measurement errors. The eccentricity of ellipse 2 will be greater than ellipse 1 but still a number between 0 and 1.



Elliptical Orbits



Name _____ Date _____

Steps

1. Tie the ends of the string together so that they make a loop.
2. Fold the paper in half vertically and draw a vertical line on the fold to locate the mid-line of the paper.
3. Determine the midpoint of the vertical fold line. Mark the point with a pencil. This point will be the center of the ellipse.
4. Tape the corners of the piece of paper to the cardboard.
5. Put the yellow push pin into the cardboard at the midpoint.
6. Place the white push pin in the cardboard 1 cm from the the yellow push pin.
7. Loop the string around the push pins.
8. Using your pencil, draw around the string, as shown in the diagram.
9. Remove the white push pin and string from your diagram and label it "Orbit #1."
10. Repeat steps 6-9 for the rest of the orbits. The second time, place the white push pin 6 cm from the yellow push pin in a different direction than the first.

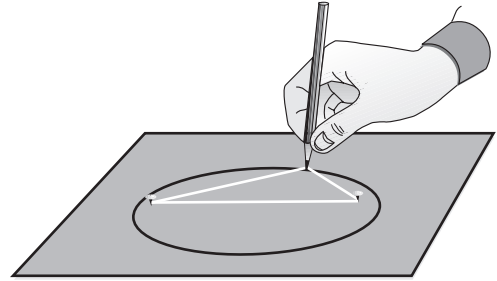

Questions

1. The orbits of the planets and comets around the Sun all are shaped like ellipses. Ellipses have two _____ .
2. Measure the length of the major axes of each of the three orbits, in centimeters. Record your answers in the table below. To ensure that you measure the full length of the major axis, line up your ruler along the ellipse's foci.

$$\text{Eccentricity} = \frac{\text{Distance between foci}}{\text{Length of major axis}}$$

Use this equation to calculate the eccentricities of the three orbits. Record your answers in the table below.

Orbit	Distance Between Foci (cm)	Length of Major Axis (cm)	Eccentricity
Orbit 1	1 cm		
Orbit 2	6 cm		
Orbit 3	7 cm		

3. According to Kepler's First Law, what object in the Solar System should one of the foci represent? _____ .
4. A circle is a form of ellipse with its eccentricity equal to _____ .

Why . . .

In our Solar System, objects orbit the Sun in paths that are shaped like ellipses, with the Sun at one of the focal points. Some of the orbits in the Solar System are shaped more nearly like a circle and others have a more eccentric orbit. In other words, the focal points of their ellipses are farther apart. Some comets have very eccentric orbits, traveling near the Sun during part of their orbits, and beyond the outer planets at other points in their orbits. Knowing about orbits helps us to predict the positions of planets and chart courses for spacecraft.





STARDUST's Rendezvous with Comet Wild 2

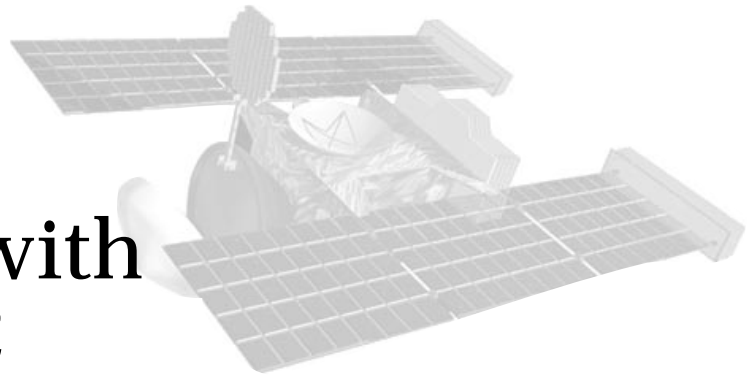

This section does NOT address orbital mechanics. Sending a spacecraft to encounter a comet, a planet, a moon, or an asteroid is a complicated process. Some targets are bigger than others, and they move at different speeds. In addition, Earth is spinning on its axis and moving along its orbit. The STARDUST spacecraft actually circles Earth twice for a gravity assist, which acts like a slingshot propelling the spacecraft to Comet Wild 2's orbit. That is all the mention orbital mechanics will receive in this activity guide.

As a spacecraft makes its final preparations to reach its destination, navigational communication plays an essential role. In this section, students will fly the STARDUST spacecraft to encounter Comet Wild 2 using simple grids and robotic toy cars. This will help to make the point that remote robotic communication and navigation face similar challenges.

- ◆ **Feedback Loop** - Challenges students to control a spacecraft (i.e., a robotic car) through remote commands (via walkie talkies) to perform required operations (knock over dominoes) to control the spacecraft.
- ◆ **Navigation Simulation** - Allows students at command center (the main room) to explore an offsite area (partitioned-off section of the room) using video cameras, walkie talkies, and a grid, and reach a destination (the comet).



Feedback Loops

Timeline

1 class period

Key Question

How do feedback loops help a scientific mission?

Overview

Many navigational systems depend upon feedback loops. Controlling a robot requires a two-way flow of information between the robot and the controller. Information going from the robot to the controller is called *feedback*, and the flow of information moving both ways is called a *feedback loop*. STARDUST, a spacecraft that will rendezvous with Comet Wild 2 in 2004 to collect samples from its coma, will use feedback supplied by a camera to help it navigate towards the comet.

Objectives

- ◆ Remotely operate a vehicle.
- ◆ Use a feedback loop to modify the vehicle's movements.

Preparation

Well in advance of the activity, assemble enough remote-controlled cars so that each team has one to work with. If necessary, request that students bring personal remote control cars from home.

Management

Remote-controlled cars can be extremely exciting, especially for younger students. It may be wise to allow one recess period for students to play with the cars. This will hopefully serve dual purposes: it gives students unfamiliar with the toys a chance to experiment and discover, and at the same time reduces some of the energy associated with the novelty of the cars.

Materials Needed

For each group of students:

- Small, radio-controlled vehicle
- Ten dominoes or blocks
- Tape
- Meter stick
- Stopwatch



Procedure

PART 1 INTRODUCTION

1. Explain to students that the spacecraft's maneuverability depends upon feedback, or the transmission of signals between the spacecraft and its mission control. An array of sensors determines the spacecraft's exact location and relays this information to a navigational computer system. The computer processes this data and determines if the spacecraft is on course. Adjustments to the spacecraft's position are made automatically through the transmission of commands to the vehicle's thrusters.
2. Explain that in order to supervise the spacecraft's programmed navigation, the mission control operator closely monitors the information displayed by the spacecraft's sensors. This feedback information supplies the operator with precise details about the position and movement of the spacecraft.
3. The human operator can use a joystick to modify the programmed spacecraft path. But all human input, or supervisory control, must first be processed and integrated by the computer system. If the system "approves" of the course input, the new commands are transmitted to the thrusters.

PART 2 LESSON DEVELOPMENT

1. Assign students to cooperative groups. In each group of four, have Student A use a meter stick and tape to mark off a square area of the floor about 2 meters on each side. Explain that the taped area represents the spacecraft's field, or "envelope of operation."
2. Have Student B place 10 dominoes or blocks in a random pattern within the marked-off square.
3. Tell Student C that his or her role will be to knock over as many dominoes as possible with the radio-controlled vehicle. Give students time to examine the placement of dominoes. Then have Student B place the vehicle anywhere within the square.
4. Have Student C stand about a meter from the square facing away from the dominoes and the car. Students A and B should take positions on opposite sides of the square.
5. Student D will use a watch to keep time. On Student D's signal, Student C will use the controls to drive the car *without* watching its movement. (**NOTE:** If the car travels out of the square, Student A or Student B is to return it to its starting location.)
6. At the end of two minutes, Student D will stop the activity and students will count and record the number of fallen dominoes.
7. Now repeat steps 2 through 6. On this second run, however, permit operators to watch the movements of their radio-controlled vehicles.
8. Exchange roles so that every student gets a chance to control the car with and without a feedback loop mechanism (with and without watching and responding to its movements).





PART 3 CONCLUSION

1. Discuss the difference between the motion of the unwatched car and its purposeful movement when the operator is able to observe its course and make corrections. Explain that the second kind of operation illustrates a feedback loop—the operator provides data to the machine; the machine provides data (or feedback) to the observing operator; and the operator supplies more data (further feedback) in response. Without feedback it would be unlikely for the car to strike all ten dominoes within a short period of time.

Reflection Questions

1. How did watching the car while you controlled it change the outcome of the demonstration?
2. How would this situation change if the remote-controlled car were several million miles away?
3. Why haven't we sent astronauts to study a comet up close?
4. How does this exercise compare to navigating the STARDUST spacecraft to comet Wild 2?



Navigation Simulation



Overview

In the context of small bodies, the navigation camera on board the STARDUST spacecraft will allow scientists and engineers to steer the spacecraft within the coma of Comet Wild 2 in 2004. To adapt this activity to reflect this, have the students navigate a remote-controlled car (the spacecraft) across a grid that represents space and the parts of a comet. Students must seek out the comet, and more specifically its coma. Have them deploy a collection device and capture cometary particles, and later stow these particles within the spacecraft.

Objectives

- ◆ Construct a floor grid for tracking movements and discoveries.
- ◆ Simulate exploring space with the spacecraft, playing the roles of the control crew.
- ◆ Compare telepresence to the interaction of the spacecraft and the operator and to their own downlink site experience.

Preparation

Collect the materials necessary for this lesson well in advance. If walkie-talkies are unavailable at school, ask students to bring some from home.

Management

Be sure to assign the operation of the video camera to someone who is familiar with how they work. Alternatively, allow time before the activity for students to practice using the camera.

Materials Needed

- Movable partition
- Copies of the Vent Field Grid, redrawn if necessary to fit space available, one for every student or team except the spacecraft operators
- Masking tape
- Meter sticks
- Index cards for floor grid location codes
- Video camera with display monitor and long connecting cable
- Walkie-talkie
- Traffic cones, funnels, or other items to simulate space features
- Bag to simulate a collection device
- Remote-controlled car



Timeline

1 to 2 classes

Key Question

How does telepresence affect a scientific mission?



Procedure

PART 1 ROOM SETUP

Note: Room setup may be done with the assistance of students, or in advance by the teacher to save class time.

1. Partition classroom into two areas. One area will be the exploration area (EA) that the spacecraft explores; the other will be the mission control (MC).
2. Mark the floor of the exploration space with masking tape to form a grid of squares. Squares 0.5 meter x 0.5 meter are ideal. Use a 4-square x 6-square area as in the pattern on the field grid, or redraw the pattern to fit the space available. In either case, be sure the paper grid matches the floor grid. Label columns A, B, C, and D across, and 1, 2, 3, 4, 5, and 6 down. Each grid square now has a location code-A1, A2, and so on. Mark one index card with each location code and place a card in the lower right hand corner of each square so it can be observed by the camera.
3. Prepare the exploration area (EA). Furniture and objects should remain in the room, but rearranging the room so the explorers will encounter new objects or usual objects in unexpected places will heighten suspense and create more focused observation. Place cones or funnels and items representing organisms in one of the grids in such a way that the command center operators and observers will recognize them as a target of the exploration.
4. Set up the monitor on the command center. Be sure that students in this area cannot see into the exploration area. Divide students into teams of seven.
 - ◆ **Site Coordinator** (MC): directs the command center
 - ◆ **Assistant Site Coordinator** (MC): marks areas on the paper grid as they are explored
 - ◆ **Command Operator** (MC): views the display screen and issues directions to the spacecraft over the walkie-talkie
 - ◆ **Spacecraft** (EA): is controlled by operators and manipulators:
 - Spacecraft's "Ears" Operator** (EA): holds the other walkie-talkie so the spacecraft operator can respond to directions
 - Spacecraft Manipulator 1** (EA): moves the spacecraft as directed by "Ears"
 - Spacecraft Manipulator 2** (EA): walks behind the spacecraft and uses his/her arms and hands as the command center directs (This student should have a bag or box in one hand to store objects collected.)
 - Spacecraft Camera Operator** (EA): operates the video camera in close-up mode
 - ◆ **Command Center Crew** (All remaining students-MC): mark locations of all objects on their vent field grids and trace the spacecraft's movements.
5. As the first team is navigating the course, distribute field grids to the remaining teams. Have each team design a course for one of the other teams to navigate.



PART 2 INTRODUCTION

Ask: How will the spacecraft be controlled? (The spacecraft's operator will direct its movements from the shipboard control panel by maneuvering a joystick for accelerating, tilting, and turning.) What will the operator have the spacecraft do when they find something of interest? What will the other scientists do? If they find something they want to see again, how will they know where to look or know where to tell someone else to look? (Students will learn the answers from this activity.)



PART 3 LESSON DEVELOPMENT

1. Instruct Spacecraft Manipulator 1 to begin anywhere on the vent field grid and turn on the camera. Command center turns on the display. Using the walkie-talkie, the Command Operator directs the spacecraft around the room. The Assistant Site Coordinator traces the spacecraft's movement on the paper grid and the command center team speculates on what they see and decides where the spacecraft should go next.

If the Command Team members want the spacecraft to pick up something for closer observation or bring it back, they must direct the spacecraft's Ears and he or she must direct the manipulators: move right, move left, move up, close fingers, put in box, and so on. The simulation continues until the vents are found or only 10 minutes remain in the class period.

2. Reinforce the concept of *telepresence*. Observe the command center group and watch for a point at which the students get so involved in the task in the command area that they appear to feel more "present" in the vent field than at the command center. The control (changing the spacecraft's direction) and feedback (watching the picture change as the spacecraft is moved) begin to convey a sense of "being there," as the operator concentrates on taking part in the scene. Stimulate discussion of that sensation. It is what Dr. Ballard, founding chairman of the JASON Foundation for Education, calls *telepresence*, and what he hopes students will experience during their visit to the downlink site (<http://www.jasonproject.org>).

Reflection Questions

1. Discuss the simulation with the class. Ask: How was it similar to the STARDUST mission? How was it different? What kinds of improvements would have made it easier?
2. Tell students that the grid they used is similar to ones scientists use. What purpose does the grid serve? (Because the command center can view only a small area, it would be difficult to relate to the larger scene without a grid for reference. Imagine doing a 5,000 piece jigsaw puzzle without the picture on the box!)
3. What difficulties are introduced when the spacecraft you are navigating is several million miles away? How does this affect the speed of communication? How do you think that scientists compensate for this?





	A	B	C	D
1	A1	B1	C1	D1
2	A2	B2	C2	D2
3	A3	B3	C3	D3
4	A4	B4	C4	D4
5	A5	B5	C5	D5
6	A6	B6	C6	D6



Spacecraft Design & Testing

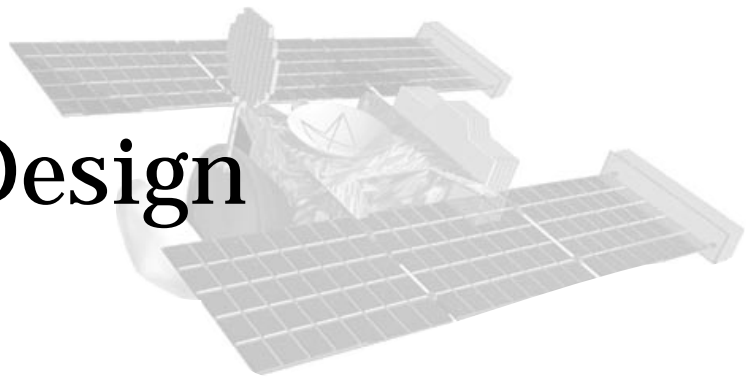

Careful spacecraft design and testing ensure the success of a mission. Some factors that enter into the design include:

- ◆ Weight- The heavier the spacecraft, the more expensive it is to launch.
- ◆ Launch stresses - The instruments need to be sturdy enough to survive the force of rocket liftoff.
- ◆ Temperature extremes - In the hostile environment of space, the side of the spacecraft facing the Sun reaches temperatures of 120°C (248°F), while the other side plummets to -120°C (-184°F).
- ◆ Mission objectives - In the case of STARDUST, instruments will: test composition of interstellar particles as well as coma particles; collect samples of each; protect the spacecraft from high-speed comet debris; and safely return the sample return capsule through Earth's atmosphere for study.
- ◆ Spacecraft operation - All spacecraft require instruments and systems to monitor the health of the spacecraft, send and receive communication with mission control, supply power, and navigate the spacecraft.

This section contains activities that examine the STARDUST spacecraft and design an effective Sample Return Capsule.

- ◆ **Candy Model Spacecraft** - Uses a variety of candies and cookies to design a model of STARDUST and discusses the operation of each part of the spacecraft.
- ◆ **Egg Drop Sample Return Capsule** - Challenges students to develop a capsule with comet and interstellar particles (an egg) to re-enter Earth's atmosphere – that is, survive a two-story (30-foot, or 9-meter) fall – and return safely (without breaking) to Earth.

Candy Model Spacecraft



Overview

Students work in teams or individually to build the STARDUST spacecraft from candy, cookies, and popsicle sticks. Each student becomes a specialist, researching the function of part of the spacecraft.

Objectives

- ◆ To build an edible model of the STARDUST spacecraft.
- ◆ To identify the technology used on board the STARDUST spacecraft.

Preparation

This activity may be done individually or in teams of 3-4 students. Reproduce the STARDUST Spacecraft Fact Sheets for each team or individual. Fill a paper lunch bag with snack-size baggies of the materials listed below for each team. One can of icing can be separated into mini papercups and covered with plastic wrap. Many grocery stores sell cookies and candy in bulk, which is less expensive and which allows you to get as much or as a little of an item as you need.

Materials Needed

Try an assortment of the following candies and cookies:

- Graham crackers, sugar wafer cookies, rectangular crackers, or chewing gum in foil (Solar Arrays)
- Plain chocolate bars or mini chocolate bars, unwrapped gum (Dust Flux Monitors/Whipple Shields)
- Lollipops (Aerogel Dust collector)
- Mini peanut butter cups and large marshmallows (Sample Return Capsule)
- Small boxes of candy: Nerds, M & Ms, Good & Plenty (Main Body of Spacecraft)
- Small coated candies or cake decorations (Navigational Camera)
- Ready-made icing in tubes or a tub
- Toothpicks, popsicle sticks, pretzel sticks, wooden skewers
- Pretzel sticks, Twizzlers (Cometary and Interstellar Dust Analyzer)
- Toothpicks with small peanut butter cups or Rolos (Antennae)
- Peppermint patty (Launch Adapter)
- Construction paper to label parts
- Paper towels
- Brown lunch bags
- Small paper cups
- Plastic wrap
- Plastic snack bags
- Plastic gloves

Timeline

1-2 class periods

Key Question

What are the main parts of the STARDUST spacecraft?

What function does each part serve?



Management

This activity works well when done with individuals as well as in teams. Remind students that they will present their spacecraft to the class, so they are not to eat all of the candy. Icing holds the smaller parts together very well.

For stability, the solar arrays need to be connected to the body of the spacecraft. Toothpicks may not be appropriate for younger students to use. Try pretzel sticks, lollipop sticks, or popsicle sticks with icing.

You may want to take pictures of the spacecraft for each student to take home, or to put on a class or school webpage.

Procedures

1. Review the STARDUST mission to Comet Wild 2. (See the STARDUST Fact Sheet.)
2. Students will make a model of the STARDUST spacecraft.
3. Have students arrange desks into teams or work individually.
4. Have a student pass out a copy of the Spacecraft Fact Sheets to each group or individual.
5. Team members will do a jigsaw with the parts of the spacecraft, where each team member becomes the “expert” for one or more parts of the spacecraft. They are to read about the part on the fact sheet and then share their information with the group.
6. Pass out the bags of candy. Tell the teams that they will now build a model of the STARDUST spacecraft with the items in the bag.
7. Once the spacecraft is built, they will need to label the parts using toothpicks and construction paper labels.
8. Make a class presentation about how the spacecraft operates during the mission. Have the teams share their spacecraft models with each group explaining one part and its function to the class.
9. Direct students to clean up supplies.

Reflection Questions

1. What did you learn about the STARDUST spacecraft that you found interesting?
2. What are the major parts of the spacecraft?
3. What does each part do?
4. What was difficult about making your model?
5. What do you like best about your model?
6. Are there more instruments on STARDUST to do the cometary science or to operate the spacecraft? Why is that?





Spacecraft Rubric

A completed spacecraft should contain the following: 3 antennae, 2 solar arrays, 1 aerogel collector, 1 Whipple Shield, launch adapter, CIDA (dust analyzer), sample return capsule, and a 3-part camera.

Use the rubrics below to evaluate your students' model spacecraft.

- 4 = Complete, fully developed, everything accounted for. Very accurate, shows a high level of creativity.
- 3 = Mostly complete, most things accounted for, accurate, creative.
- 2 = Partly complete, parts are missing, some inaccuracy, shows very little creativity.
- 1 = Missing or omitted parts, mostly inaccurate, poorly put together.
- 0 = Did not create a model.

Presentation Rubric

Use the rubric below to evaluate the students' spacecraft presentations.

- 4 = All parts labeled, functions defined, student's explanation is clear and accurate.
 - 3 = Most parts labeled, some functions defined, explanation clear and accurate.
 - 2 = Some parts labeled, few or no functions defined, explanation confusing and inaccurate.
 - 1 = Few parts labeled, functions not defined, little or no explanation.
 - 0 = No presentation.
-



Egg Drop Sample Return Capsule



Overview

In 2006, the STARDUST mission will be the first mission to bring back captured particles of a comet's coma for scientists to study. The particles will be safely embedded in the aerogel dust collector and stowed in the Sample Return Capsule (SRC). The SRC is an aerodynamic canister with a heat shield, hinge, avionics equipment, double parachute system, and of course the sample container. It must withstand the heat of re-entering Earth's atmosphere, deploy a double parachute, and land intact in a dry lakebed in Utah, in order to bring these clues back to Earth.

Objectives

- ◆ Design and test a Sample Return Capsule to keep an egg from cracking when dropped from a second-story window.
- ◆ Calculate the components of free fall, including: time, speed, and distance.

Preparation

Be sure to get the approval of the principal to conduct this activity. Send a note home prior to the activity to collect a supply of materials needed.

Management

Have students work in teams of four. For younger students, the emphasis of the challenge can be steered away from calculating forces of gravity and placed on the strength of structure shapes. For example, circles and triangles are stronger structures than rectangles and squares.

Materials Needed

- | | |
|---------------------------------------|---|
| <input type="checkbox"/> Straws | <input type="checkbox"/> Thread |
| <input type="checkbox"/> Paper towels | <input type="checkbox"/> Paper |
| <input type="checkbox"/> Cottonballs | <input type="checkbox"/> Tape measure, yardstick, etc. |
| <input type="checkbox"/> Plastic bags | <input type="checkbox"/> Drop cloth |
| <input type="checkbox"/> Eggs | <input type="checkbox"/> Stop watch |
| <input type="checkbox"/> Scissors | <input type="checkbox"/> Styrofoam and cardboard containers |
| <input type="checkbox"/> Wire springs | |

Procedures

1. Set the scene properly, before you bring up the topic of the egg drop. The discussion should center around the problems of the Sample Return Capsule surviving re-entry into Earth's atmosphere and the impact of landing.
2. Which variables can be controlled? Which can be measured? Which can be calculated? One should discuss which factors have the greatest influence upon the forces of impact and which do not.

Does the mass of the package have any effect? What about the dimensions and shape? What about the falling distance? What about the falling time? What about



Timeline

3 to 5 classes

Key Question

What structures are strong enough to protect a raw egg from breaking when it is dropped from a two-story building?



the amount of weight crushing of the container? What was the average velocity? What was the terminal velocity? The total amount of “g” force absorbed by the package? Did the package or the payload absorb the force?

These are some of the factors which should be discussed before deriving a formula to determine the g forces of impact from those values which can be easily measured.

- 3. Introduce the exploration challenge: This is an exercise in using one’s ingenuity to package a delicate object (the egg represents the aerogel dust collector holding interstellar and comet dust particles) to withstand impact or a high “g” force by dropping it from a two-story window.

Their task is to package a raw egg in a container no larger than 6 x 6 x 6 inches (15 x 15 x 15 cm), (perhaps a hamburger box or some container which is easily obtained) so it can be recovered unharmed (the shell and the yolk should not be broken) when dropped from a 2-story window (height of at least 30 feet).

- 4. Break the class into teams of 3 or 4 students. Give students one to three class periods to explore the effects of changing container designs.
5. Drop the package from the given altitude.
6. Make appropriate measurements as indicated below.

Calculate the g forces of impact.

FORMULA TO DETERMINE g FORCES ON FALLING EGG

Input: DF = Distance of fall (in feet)

TF = Time for fall (in seconds)

Output: g = D/32 ft per second per second

- 7. Recover packages and bring them to a central site for opening.
8. Examine the contents of the package to determine the various levels of success:
- Shell intact, yolk intact: complete success.
- Shell intact, yolk broken: partial success
- Shell broken, yolk intact: partial success
- Shell broken, yolk broken: mission failure
9. Discuss the results as a class.

Reflection Questions

- 1. How many teams had complete success with their SRC? How many teams fall in each scenario listed in procedure 8? Convert these numbers to percentages.
2. What characteristics do stronger containers have?
3. What structures did not work well?
4. How would you redesign your container based on lessons learned from acquired data?
5. How does this egg drop experiment relate to the STARDUST mission?
6. Have humans ever brought back samples from a body in the Solar System?



Table with 2 columns and 4 rows defining variables: AV = Average Velocity, TV = Terminal Velocity, D = Deceleration, G = g forces, AV = DF/TF, TV = 2 x AV, TC = 2 x CD/TV, D = TV/TC

Egg Drop Sample Return Capsule Worksheet



Team _____ Date _____

_____ Class _____

Your Mission:

Package a raw egg in a container no larger than 6 x 6 x 6 inches, so it can be recovered unharmed (the shell and the yolk should not be broken) when dropped from a 2-story window (height of at least 30 feet).

1. How will you protect the egg? _____

2. Draw a sketch of the container, label all key elements.

3. Why did you choose this design? _____

4. What happened when you tested your team's design? Explain. _____



Technology For Studying Comets

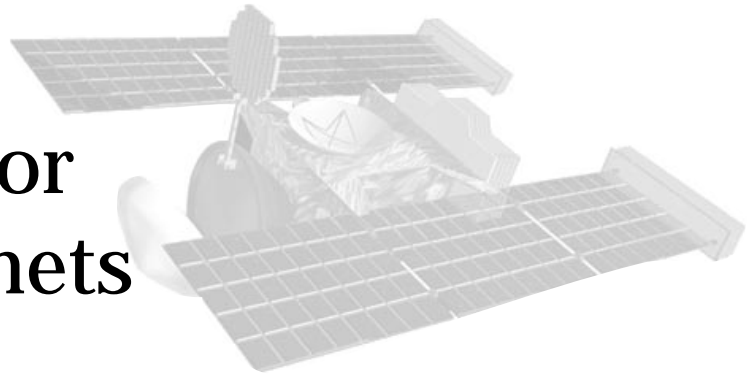

The instruments on board the STARDUST spacecraft will analyze particles during the mission, take images using the navigation camera, and most exciting of all, capture particles to bring back to Earth for analysis. This section contains two activities that focus on the technology that allows astronomers to study Comet Wild 2 in depth.

Aerogel Clay Collector - Investigates how to capture a high-speed particle (a large clay ball, thrown) without damaging it by using various materials. Teams design a capture device, write up experiment directions, and seek to reproduce experimental results.

Paint By the Numbers - Explores how an image is turned into data, transmitted to mission control and reassembled into an image back on Earth.

Aerogel Clay Collector Activity Overview

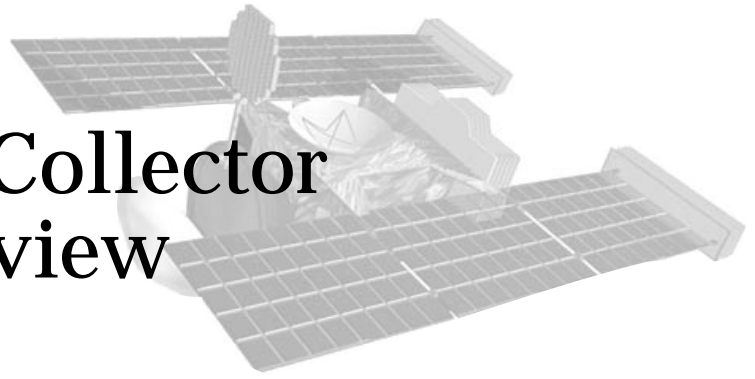

Overview

This activity offers a simple approach for “experiencing” aerogel. Aerogel is an amazing feat of technology that will be used by the STARDUST spacecraft to capture high-velocity interstellar dust and particles from the coma of comet Wild 2. Students design and conduct an experiment to capture a fast-moving particle of clay without changing its shape or composition.

- Part 1 Students investigate the characteristics of clay, examining what happens to a ball of clay that they drop under different conditions. The teacher then associates investigating falling clay to capturing a particle from a comet.
- Part 2 The teacher reviews parts of the comet and introduces the STARDUST mission.
- Part 3 This demonstration uses gelatin and lead pellets to show how the spacecraft’s aerogel collector will capture comet particles.
- Part 4 Student teams examine mediums to capture a falling clay ball without changing it and then design a collection device. They also write the directions for conducting the experiment using this device.
- Part 5 Teams evaluate each other’s directions based on set criteria.
- Part 6 Finally, teams test the highest scoring direction design by doing the experiment and then share their findings with the class using visual aids.

Time Line

- Part 1 = one class
- Part 2 = one to three classes depending on variations
- Part 3 = one class
- Part 4 = one to three classes each depending on the depth of exploration desired.
- Part 5 = one class
- Part 6 = two classes

Objectives

1. To tie experimental design into a real-world context using aerogel from the upcoming STARDUST mission.
2. To design a device that captures a falling clay ball without changing its characteristics while exercising good practices for conducting an experiment.
3. To apply principles of the scientific process by planning an experiment and communicating it by writing directions.
4. To use a peer review process to evaluate an experimental design based on criteria.
5. To conduct the experiment and verify the results through replication.
6. To present the findings using written and oral communication skills.



Notes

Key Question

How do you capture a fast-moving object without changing its characteristics?

Preparation

Students should be familiar with parts of a comet, the way they move through the Solar System, the scientific process, and controlling variables. We recommend doing the activity *Cookin' Up a Comet* before doing this lesson.

Materials Needed

PART 1: CHARACTERISTICS OF FALLING CLAY

Teams of 3-4 students need:

- Paper towels or newspaper to cover the floor
- A golf ball-size clay ball (use modeling clay)
- Powdered seltzer tablets (optional - See Management for Older Students)
- Student worksheets entitled "Clay Impacts"

PART 2: INTRODUCTION TO COMETS & STARDUST MISSION

Use some combination of these materials:

- The Comet Fact Sheet
- If available from NASA CORE, show the videotape *STARDUST Bringing Cosmic History to Earth*.

PART 3: AEROGEL

For the aerogel-lo demonstration you will need:

- 1 packet unflavored gelatin
- Hot water
- Two clear plastic cups (NOT the soft, opaque plastic ones)
- A spoon
- A plastic straw
- A scrap of clean pantyhose and tape to secure it (optional)
- Lead pellets (available at sporting goods stores)
- Safety goggles for you and all students
- Aerogel Fact Sheet



PART 4: DESIGN COLLECTOR & CREATE EXPERIMENT DIRECTIONS

Teams will need:

- Clay ball
- Newspaper or paper towels
- Assorted materials for collector (See management section for details.)
- Worksheets entitled Design Collector and Create Experiment Directions

PART 5: EVALUATE EXPERIMENTAL DESIGNS

Teams will need:

- Copies of other team's directions
- Experiment score sheet

PART 6: DESIGN TESTING & FINDINGS PRESENTATIONS

Each team will need:

- A set of directions for the chosen experiment
- Materials listed for the experiment
- Posterboard
- Markers
- Rulers



Management

The activity designers assume that the teacher will use this activity to introduce STARDUST to students. If the teacher will be doing other STARDUST activities with the class, then Part 2 may be unnecessary. We leave it to the teacher's discretion as to which parts to skip and which to include. Check the beginning of each part for tips on how to modify the section for younger or older students.

Completion time for the aerogel activity can be scaled back to one class for younger students or increased to five classes so older students can really delve into experiment design and testing.





Part 1:

Characteristics of Falling Clay

Part 1 is the hook of the activity. Here students explore the characteristics of clay when it falls. They identify and control variables and use the results to develop a “profile” on falling clay that they will use in parts 3-4.

Materials Needed

Teams of 3-4 students need:

- Paper towels or newspaper to cover the floor
- A golf ball-size clay ball (use modeling clay)
- Powdered seltzer tablets (optional - See Management for Older Students)
- Student worksheets entitled “Clay Impacts”

Procedure

1. Explain to the class that they will conduct a scientific investigation of a moving object to determine its characteristics. Show the ball of clay. Their task is to carefully observe and record what happens to a falling ball of clay under different conditions.
2. Have the class review how to make careful observations by describing characteristics of the clay ball. Responses should describe factors like:
 - ◆ shape
 - ◆ size (like a golfball, estimate diameter)
 - ◆ color
 - ◆ weight (light/heavy, estimate grams)
 - ◆ temperature (warm or cold)
 - ◆ texture (soft and malleable or hard)
3. Part of the object’s characteristics has to do with what happens to it when it hits the ground. Students will work in teams of 3 or 4 to test what happens to the ball under different conditions and make careful observations.

They need to identify and control variables so they can write a profile on clay. For example students can drop the clay from different heights, at different speeds, on different surfaces, at different temperatures. It is up to the students to test only one variable at a time and provide detailed descriptions of their results. The worksheet will help teams record their results.

Teams will use their results to design a device that can capture the ball without altering it in any way.



4. Have students form teams of 3 or 4 and arrange desks accordingly. Each member has a role with specific responsibilities listed on their worksheets. Have teams send one member to get materials.
5. Allow teams to conduct their investigations. Float between teams, observing how carefully they control variables. Encourage students to ask their teammates questions first before coming to you.
6. Have teams clean up the experiment.
7. Use the last ten minutes of class to have each team's reporter share their profile on the nature of falling clay based on their experiments.

Students' profile on what happens to falling clay should conclude that clay is *malleable*. It changes shape easily. The faster the clay hits the ground, the more the shape changes. This has to do with the energy converted from dropping the clay.

Reflection Questions

1. How do you describe the characteristics of your falling object?
2. What precautions did teams take to control variables in their experiments?
3. What was difficult about controlling variables?
4. What would your team do differently?
5. If more time was available, what would you like to try next?
6. What did you learn from doing this activity?
7. How does this activity relate to what scientists do?
8. If an asteroid or comet hit Earth, how do you think its characteristics would change?

Wrap Up

If a small delicate object travels at very high speeds and hits something, what happens? Do its characteristics change? How could you capture it?

This is what the NASA mission called STARDUST will do. In the next class we will discuss this mission and how it will capture particles from a comet without damaging them. Then teams will design a device to capture a falling ball of clay without changing it in any way to simulate how aerogel will capture particles during the STARDUST mission.





Part 2:

Introduction to Comets & the STARDUST Mission

Now that the students are hooked, it is time to relate the clay to comet particles. To do so, review the subject of comets with them. Progress to the STARDUST mission, and introduce the kind of technology needed to capture moving particles.

Materials Needed

Use some combination of these materials:

- The Comet Fact Sheet
- If available from NASA CORE, show the videotape *STARDUST Bringing Cosmic History to Earth*.

Procedure

COMETS

1. Find out what students know about comets and how they travel through the Solar System. Do the students hold any misconceptions?
2. Discuss parts of the comet and the manner in which they travel through the Solar System. See the Comet Fact Sheet for details.

Once in the inner Solar System, the comet's nucleus begins to sublimate, ejecting vast quantities of particles of dust and gas. Ices normally turn to liquid. From a liquid state a substance can turn to a gas. This is known as evaporation. When a solid turns directly to a gas, this is known as sublimation.

This forms a coma around the nucleus. Charged particles from the Sun push the coma into two tails - a gas tail and a dust tail - that stream away from the Sun. These gas and dust particles in the tail are very small - smaller than grains of sand - and move at high speeds.

3. Ask the students how much they think scientists know about comets.

The truth is, our understanding of comets is not as detailed as you might think, because comets are difficult objects to study. Comets can have huge orbits. Some spend hundreds of years past the outermost planets. During this time comets are commonly hard to see because they are small and dark. Compared to planets comets are small - generally less than the size of a city. Comets usually grow tails when they are in the inner Solar System because they are closer to the Sun's heating rays, making them easier to see.

Much of what we know about comets comes from ground-based observations. We know something about the parts of comets and we can predict their orbital motions. We have even witnessed a comet (Shoemaker-Levy 9) hitting Jupiter back in July 1994. However, spacecraft have only studied one comet (Comet Halley) and



that was back in 1987. Many theories about comets exist, including the debate over whether or not a comet's nucleus is solid. Scientists seek more information on this subject since future missions are proposing to land a probe on a comet. An ideal way to learn about the composition of comets is to capture particles from a comet and return them to Earth for study.



4. Ask students why studying comets is important.

Comets are important because they:

- ◆ Provide clues as to how our Solar System formed. They are the oldest, most primitive bodies in the Solar System, dating back to its formation.
- ◆ Possibly act as building blocks of planetary systems around the stars.
- ◆ Bring volatile elements (ices) to planets that may play a part in the formation of oceans and atmospheres.
- ◆ Contain organic materials that may play a role in the origin of life on Earth or other planets.
- ◆ Can cause major changes in climate and ecosystems if they hit Earth (they might have led to the extinction of the dinosaurs and other types of life).

STARDUST

1. Discuss the STARDUST mission with students.

STARDUST launched in 1999. It will get a gravity assist by looping around Earth to slingshot toward the comet. En route the spacecraft will go around the Sun twice, collecting interstellar dust. In 2004 STARDUST will fly through the coma of comet Wild 2 where gas and dust spew forth. The comet is named Wild 2 because it was the second comet discovered by the Swiss astronomer Paul Wild. Professor Wild's name is actually pronounced "Vilt" in his native language (German). Within 100 kilometers of the comet's nucleus, STARDUST will collect particles and take pictures of the comet's surface features.

On the return trip, the samples stored in a return capsule will separate from the main body of the spacecraft. In 2006 the capsule will re-enter Earth's atmosphere, deploy a parachute to slow its descent, and land in a dry Utah lakebed, making history.

Option: If a copy of the videotape "STARDUST Bringing Cosmic History Home to Earth" is available, it is a great addition to a classroom discussion. The video is less than 10 minutes long and contains exciting information that captures the attention of the audience.

2. Show images of the spacecraft downloaded from the STARDUST website.
3. Have students write a journal entry using the worksheet provided.

Reflection Questions

1. Which part of the comet will STARDUST fly through?
2. Why was Comet Wild-2 chosen for the STARDUST mission?
3. How will the spacecraft collect particles?
4. Why do scientists want to study these particles?
5. What were you surprised to learn about?





Part 3: Aerogel

CAUTION

This demonstration can be dangerous if not done correctly. Have your students wear safety goggles and follow the safety procedures.

Preparation

This demonstration uses gelatin and pellets to show how STARDUST's aerogel collector will capture comet particles. The gelatin is referred to as "aerogel-lo." For a successful demonstration, the gelatin must have the right consistency. Follow the directions on the gelatin packet to achieve the desired consistency. Pour the gelatin into two glasses, one for class, one for practice. Be sure to prepare the gelatin before doing the activity in class. This does two things; first it allows enough time for the gelatin to set. Second, you have time to test the gelatin and make another batch if it does not have the right consistency.

To test the consistency, attach a clean scrap of pantyhose over one end of the straw using tape. This precaution is to keep you from inhaling a lead pellet by mistake. Place a piece of lead pellet in the straw. Tip the straw so the lead slides to the covered end. Pinch the straw, trapping the lead pellet at the top of the covered end. Blow the lead pellet into the gelatin with a quick, sharp blow.

Gelatin has the right consistency if the lead pellet enters the gelatin easily, the gelatin stops the lead pellet, and the track from the lead pellet remains visible. If the lead pellet bounces off the bottom of the container, the gelatin is too watery. Make another batch of gelatin using less water. If the lead pellet bounces off the surface of the gelatin or hardly penetrates it, add more water to the next batch.

Materials Needed

For the aerogel-lo demonstration you will need:

- 1 packet unflavored gelatin
- Hot water
- Two clear plastic cups (NOT the soft, opaque plastic ones)
- A spoon
- A plastic straw
- A scrap of clean pantyhose and (optional) tape to secure it
- Lead pellets (available at sporting goods stores)
- Safety goggles for you and all students
- Aerogel Fact Sheet



Procedure



1. Ask students how they could capture particles from a comet.

Would a huge net work? Well, the particles are microscopic. How about sticky fly paper? They travel so fast that they would tear through the thin paper. How about buckets of syrup or water? Syrup or water would freeze in the vacuum of space or evaporate from the heat of the Sun. The scientists really had a problem—challenge — to find a good collecting device.

2. Collecting materials from a comet's coma is no easy feat!

The impact velocity of the particles as they are captured will be up to 6 times the speed of a bullet fired from a rifle. These particles are smaller than grains of sand. High-speed capture could alter their shape and chemical composition or vaporize them entirely.

3. Scientists needed something that would capture very tiny delicate particles without damaging the shape. The substance had to be strong to survive the launch into space, lightweight to keep liftoff costs low, and not melt or freeze in the extreme temperatures of space. Also the substance needed to be relatively see-through so the particle could be found easily.
4. Put on safety goggles and take out the cup of gelatin, straw, and lead pellets.
5. Place a lead pellet in the straw. Tip the straw so the lead slides to the covered end. Pinch the straw, trapping the lead pellet at the top of the covered end.
6. Hold the cup so students can see it or pass the cup around the room.
7. Take a big breath and at the same time, stop pinching the straw and blow the lead pellet into the aerogel-lo with a quick, sharp blow. Shoot several pieces into the cup.
8. Point out the track mark to the lead pellet. If possible, show the image of the track from the STARDUST website at: <http://stardust.jpl.nasa.gov/spacecraft/aerogel.html>
9. What is aerogel?

Aerogel is mostly transparent. Scientists refer to it as blue smoke. It is a silicon-based solid that is 1,000 times less dense than glass with a sponge-like structure, in which 99% of the volume is empty space. An inch thickness of aerogel has the insulating power of six inches of fiberglass.

Show students images of aerogel downloaded from the STARDUST website
<http://stardust.jpl.nasa.gov/spacecraft/aerogel.html>

10. When was aerogel developed?

Aerogel was discovered in the late 1930's, but it was not until the late 70's that it could be prepared in a reasonable amount of time - less than several weeks. In the early 80's, advances in making aerogel maintained its structural integrity and eliminated some safety concerns, such as working with toxic compounds and explosion hazards, in manufacturing it. Other advances in aerogel





formation during that time included a decrease in the amount of time that it took to create aerogel and the ability to form gels that were lighter, containing more air per volume.

11. How does aerogel act as a mechanism of capture?

When a particle hits the aerogel, it buries itself in the material, creating a carrot-shaped track up to 200 times its own length as it slows down and comes to a stop. Scientists will find the particle at the end of this track.

12. Have students compare the similarities between gelatin and aerogel as a capturing media for moving particles. Like aerogel, aerogel-lo stops the moving particle and holds on to it, leaving a trail, at the end of which lays the particle.
13. Discuss the limitation of the aerogel-lo model.

Models represent certain characteristics of the thing they represent, often falling short in other ways. The aerogel-lo is far more dense than real aerogel. It lacks properties needed for stopping a high velocity particle. It would not travel well in space, which has temperature extremes, due to its high water content. The weight of the gelatin is far greater than aerogel, which is 99% air.

Reflection Questions

1. What makes aerogel special?
2. How does aerogel stop a particle from a comet?
3. Why don't we insulate our houses with aerogel?
4. What did scientists and engineers have to consider when picking a material to capture comet particles?



Part 4:

Design Collector & Create Experiment Directions



Teams test materials and devise a collector to safely catch a clay ball without changing it. For younger students, try limiting the materials only to cotton balls. Have teams determine how many cotton balls and the best container shape to catch the clay ball without changing its shape.

Tell the students which materials to use. Try baking soda, water, cotton, marbles, dry beans (like split peas or lentils), or candy sprinkles to catch the clay ball. Limit the collection device to something shallow and something deep. Try either a shallow pie pan, a margarine tub, or a bucket.

For older students, teachers can use their judgment as to how much leeway to grant students for designing a capturing device in terms of materials and development time. Be sure to set limits for expense and safety issues.

A fun twist to this experiment is to add powdered seltzer tablets to the clay. The challenge is then not only to capture the ball without changing the shape, but to keep the capturing substance from changing the composition of the ball. If students use water to stop the ball, it will fizz.

Another twist is to challenge students to find a medium that will capture and hold the clay ball so it cannot escape.

Materials Needed

Teams will need:

- Clay ball
- Newspaper or paper towels
- Assorted materials for collector (See management section for details.)
- Worksheets entitled Design Collector and Create Experiment Directions

Procedure

MATERIAL TESTING

1. Particles from the coma of the comet are traveling 6 times faster than the speed of a bullet fired from a rifle. This is too fast and dangerous to replicate in the classroom, but students can imagine the clay ball traveling this speed and how flattened the shape would be on impact. The particles from the comet are actually smaller than a grain of sand, and the particles are delicate, especially traveling at high speeds.





2. Have students work in teams of 3 or 4 students to test materials for a capturing device. The device should keep the clay's shape intact. Students need to pick a material to stop the clay ball and decide on the shape and material of the container used to hold the collection substance. Have teams use the worksheet to walk them through this process.

3. Discuss what materials and containers work best, and which worked poorly.

Have the teams characterize the material as a good particle capturer if it keeps shape intact and stops the falling ball (the material not the container). Is the material:

- ◆ Thin or thick
- ◆ Solid or liquid
- ◆ Strong or weak
- ◆ Transparent or opaque
- ◆ Light or heavy
- ◆ Expensive or inexpensive

4. Discuss how these criteria relate to aerogel.

5. Teams will then decide which material to use in their collection device and bring in any materials from home that are not available in the classroom.

Collector Device Design

1. Based on what teams found out about the materials and containers for the collector device in the last part, they will refine the design of their collector devices using the Design Collector and Create Experiment Directions worksheets.

2. Before teams begin, discuss how engineers approach design changes in systematic steps, controlling variables, and alternatively skipping steps when they can infer that it is appropriate.

3. Once teams develop a collector device that works, they are ready to write the directions for their experiment using the criteria listed on the worksheet. Discuss the criteria in detail.

This exercise is important. For an experiment to be considered scientifically sound, others should be able to replicate the experiment and achieve the same results.

4. Have teams write directions for conducting their experiments. Have them attach a cover sheet with the title for their experiment and the name of the team members. These names should not appear on the direction page. (The peer review process should not be biased by the name of team members.)

Reflection Questions

1. What materials are good at catching the clay without changing it?

2. What characteristics do these materials have?

3. What properties does the container need to work well?

4. How does your collection device differ from aerogel?

5. What was difficult about finding a good material to use? Container?

6. What did you learn from designing a collector?

7. What did you learn about the scientific process by writing directions?



Part 5:

Evaluate Experimental Designs



In this part, experiments go through a peer review process where each team will score the experiment against set criteria. By committee the class will decide which experiment to test and all of the teams will then conduct the experiment to verify the results in the next class.

Materials Needed

Teams will need:

- Copies of other team's directions
- Experiment score sheet

Procedure

1. Add a title page to each set of directions that reads, "Experiment # ____." Give each experiment a number. Be sure the directions do not include the name of the team members. Make copies of all sets of directions and the Experiment Score Sheet.
2. Discuss how to use the Experiment Score Sheet with the class.
3. Pass out the sets of directions. Be sure no team gets a copy of their own directions.
4. Have teams secretly score each set of directions.
5. Share the results as a class. Discuss the merits of each team's directions and the collector design.
6. Have the class decide which experiment to replicate.
7. Give teams the option to revise their directions to improve their score. After all, writing directions is a skill best perfected with practice.

Reflection Questions

1. What was the difference between the good directions and the excellent directions?
2. With which criteria did most groups have trouble?
3. How did criteria help you "grade" directions?
4. Why is peer review important to the scientific process?





Part 6:

Design Testing & Findings Presentations

The final part of the aerogel activity stresses the importance of other scientists being able to take an experiment, do it themselves and get the same result. An experiment is not scientifically sound otherwise.

Materials Needed

Each team will need:

- A set of directions for the chosen experiment
- Materials listed for the experiment
- Posterboard
- Markers
- Rulers

Procedure

1. Have teams gather materials and set them up. The team whose experiment design was chosen floats between teams acting as consultants, answering questions.
2. Conduct the experiment.
3. Clean up.
4. Have teams write a report summarizing their findings. Teams need to present their results with a visual aid, like a poster with a graph.
5. Have teams present their findings on how well the experiment was able to be replicated. Discuss problem areas that may have influenced the outcome of each team's experiments and how to address them.
6. Tie the process the class went through in developing a collector with the challenge engineers faced when designing the aerogel collector for the STARDUST mission.

Reflection Questions

1. What happened when teams replicated each other's experiments?
2. Were the experiments well designed?
3. What problems can affect the outcome of an experiment?
4. How does this part tie into the scientific process?
5. Do you think every experiment a scientist publishes in scientific journals works?
6. Why is it important for experiments to consistently yield the same result?



Characteristics of Falling Clay



Name _____ Date _____

Before beginning this worksheet, do the following:

- ◆ Find three other students to be on your team and find an area of the classroom to sit together.
- ◆ Send one student to get clay and newspaper or paper towels.
- ◆ Roll the clay into a ball.
- ◆ Place the newspaper or paper towels on the floor.

1. Write the name next to the role each team member chooses.

- _____ **Journalist** - Writes down the group's answers on the worksheet.
_____ **Public Affairs Officer** - Presents team's findings to the class.
_____ **Engineer** - Drops the clay ball and controls variables.
_____ **Materials Specialist** - Collects and returns materials.

2. Find out what happens to clay when it falls under different conditions. Name some types of conditions, or variables, you can test when dropping the clay ball. *(For example, you can drop the clay from different heights.)*

3. Pick a variable you want to test. Design two ways to test this variable. *(For example, drop the ball from two different heights.)* Fill in the results in the chart below.

Describe Test 1: _____

What Happened: _____

Describe Test 2: _____

What Happened: _____





4. Pick another variable to test. Design two ways to test it and describe the results in the chart below.

Describe Test 1: _____

What Happened: _____

Describe Test 2: _____

What Happened: _____

5. What did you learn about falling clay? Write a profile describing what happens to falling clay under different conditions.



Student Journal



Finish the following sentence starters.

1. One thing I found interesting about comets is . . . _____

2. One thing scientists say about comets that surprised me is . . . _____

3. STARDUST is a "cool" mission because . . . _____

4. Another thing I would like to learn about the STARDUST mission is . . . _____





	Shape	Texture	Temperature	State: Clean/Dirty	Surface: (Wet/Dry/Sticky)
Material 1					
Material 2					
Material 3					
Material 4					



Materials Testing



Name _____ Date _____

Before beginning this worksheet, do the following:

- ◆ Find three other students to be on your team and find an area of the classroom to sit together.
- ◆ Send one student to get clay and newspaper or paper towels.
- ◆ Roll the clay into a ball.
- ◆ Place the newspaper or paper towels on the floor.

1. Write the name next to the role each team member chooses.

_____ **Recorder** - Writes down the group's answers on the worksheet.

_____ **Reporter** - Presents team's findings to the class.

_____ **Engineer** - Drops the clay ball and controls variables.

_____ **Materials Specialist** - Collects and returns materials.

2. Pick four materials to catch the clay ball without changing it.

List the materials below.

3. Drop the ball from the same height for each material. What happens?

Material 1 _____

Result _____

Material 2 _____

Result _____

Material 3 _____

Result _____

Material 4 _____

Result _____





Collector	Result
Include the amount of material, and the size and type of container.	Describe in detail.
1. _____	_____
2. _____	_____
3. _____	_____
4. _____	_____
5. _____	_____

4. Did the materials you use affect the ball in the following ways?

5. What materials worked best? What properties does the material have that make it work the best?

6. What other materials might work better than the ones you tried?



Collector Design



Name _____ Date _____

Before beginning this worksheet, do the following:

- ◆ Sit with your team.
- ◆ Take out the Materials Testing worksheet

1. Based on the Materials Testing worksheet, design a container to hold the material of your choice.

2. Discuss ways to modify your collector device so the clay ball does not change shape when dropped from shoulder height.

3. Gather newspaper, a clay ball, and the materials you need for your collector device. Modify your design until it works. You may not need to fill in the entire chart.

4. What characteristics of the collector device were the most important in preventing the ball from changing shape?





Create Experiment Directions

Name _____ Date _____

Before beginning this worksheet, do the following:

- ◆ Sit with your team.
- ◆ Take out the Design Collector worksheet.

An experiment is not scientifically sound if it cannot be replicated. Others should be able to do the same experiment and get the same result you did. Your task is to write step-by-step directions so anyone can do your experiment.

1. Before you begin writing directions, make a list of variables - those elements you can change that can affect the outcome of the experiment.

For example, the type of clay someone uses might be harder or softer than the clay you used.

2. Write the directions for conducting your experiment on a separate piece of paper. Clear directions meet the following *criteria*.

- ◆ Tells the purpose of the experiment and why it is important.
- ◆ Collection device seems functional and creative.
- ◆ Collection device is inexpensive and safe.
- ◆ Lists the materials needed and includes exact amounts.
- ◆ Explains tasks one step at a time.
- ◆ Steps are detailed, make sense, and are easy to follow.
- ◆ Steps are in order.
- ◆ Uses drawings when needed.
- ◆ Uses complete sentences.
- ◆ Has good grammar and proper punctuation.

Use the space below for notes before you begin writing the directions.



Experiment Score Sheet



Evaluate each experiment using the criteria below. Use the point system below. Add points up and convert to a percentage for a score.

Point System

2 points . . . Directions fully meet criteria.

1 point Directions partially meet criteria.

0 points . . . Directions do NOT meet criteria.

1. ____ Tells the purpose of the experiment and why it is important.

Comments: _____

2. ____ Collection device seems functional and creative.

Comments: _____

3. ____ Collection device is inexpensive and safe.

Comments: _____

4. ____ Lists the materials needed and includes exact amounts.

Comments: _____

5. ____ Explains tasks one step at a time.

Comments: _____

6. ____ Steps are detailed, make sense, and are easy to follow.

Comments: _____

7. ____ Steps are in order.

Comments: _____

8. ____ Uses drawings when needed.

Comments: _____

9. ____ Uses complete sentences.

Comments: _____

10. ____ Has good grammar and proper punctuation.

Comments: _____

____ Total Points X 5 = ____ %



Paint by the Numbers



Notes

Overview

A pencil and paper activity demonstrates how astronomical spacecraft and computers create images of objects in space. It simulates how light collected from a space object converts into binary data and reconverts into an image of the object. STARDUST will use the same principles to transmit images of the comet's coma to scientists on Earth.

Objectives

- ◆ Convert an image into binary code.
- ◆ Reconvert binary code into an image.

Preparation

Make enough copies of the transparent grid, the paper grid, and the picture of the house for each pair of students

Materials Needed

For each pair of Students

- Transparent grid
- Student A: You are the Spacecraft Worksheet
- Student B: You are Mission Control Worksheet
- Pencil
- Tape

Management

Older students can make the exercise more complex using a finer grid. The finer the grid, the greater the detail the final image has. However, this also means that the process is more tedious. Likewise, younger students can use a larger grid with a less detailed image as a result.

Procedure

1. Divide students into pairs.
2. Give one student (A) in each pair the Student A Worksheet and a transparent grid. Give the other student (B) the Student B Worksheet. Instruct student A not to reveal the picture to student B.
3. Explain that the picture is an object being observed at a great distance. It will be scanned by an optical device like those found on some astronomical satellites and an image will be created on the paper.



Timeline

1 class

Key Question

How do spacecraft convert images into bits of data and then convert them back to images?

- Have student A place the grid over the picture. Student A should look at the brightness of each square defined by the grid lines and assign it a number according to the chart above the picture. Student A will then call out the number to student B. If a particular square covers an area of the picture that is both light and dark, student A should estimate its total brightness and assign an intermediate value to the square such as a 1 or a 2.

Note: The letters and numbers on two sides of the grid can assist the receiving student in finding the location of each square to be shaded.

- After receiving a number from student A, student B will shade the corresponding square on the grid. If the number is 0, the square should be shaded black. If it is 3, the square should be left as it is.
- Compare the original picture with the image sketched on the paper.
- Use the following information to discuss with students the context of this activity.

The image created with this activity is a crude representation of the original picture (see house 2 at right). The reason for this is that the initial grid contains only 64 squares. If there were many more squares, each square would be smaller and the image would show finer detail (see houses 3 and 4 at right). You may wish to repeat this activity with a grid consisting of 256 squares. However, increasing the number of squares will require more class time.

This activity shows how astronomical satellites such as the Hubble Space Telescope (HST) produce simple black and white images. Pixel stands for “picture element” and refers to one of the squares in the grid. With the HST, the grid consists of more than 2.5 million pixels and they are shaded in 256 possible shading variations to create the image.

Color images of an object are created by the HST with color filters. The spacecraft observes the object through a red filter, a blue filter, and then a green one. Each filter creates a separate image, containing different information. These images are then colored and combined.

- Conclude the lesson with Reflection Questions.

Reflection Questions

- How did the transmitted image change from the original picture?
- What do you think would happen if the grid squares were bigger? Smaller?
- How does making the grid squares smaller make it more difficult for scientists and engineers to transmit information?
- What does it mean if a rectangular section of an astronomical image appears black?
- What other factors besides number of pixels per area can affect the detail of an image?



House 2

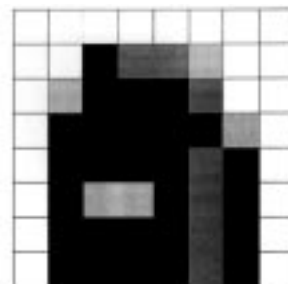

House 3

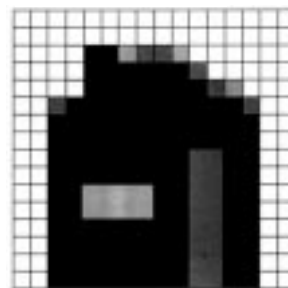

House 4

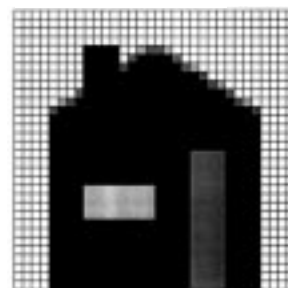



Student A: You are the Spacecraft.

Your job is to change the image into data and transmit it to Mission Control (your partner).

1. Lay the transparency of the grid on top of the picture. Tape it in place.
2. Find Row A Square 1. Decide which value this square has.
3. Send this information to Mission Control. Tell your Mission Control Partner:

Row ____ Square ____ Value ____

4. Repeat this process for each square of the grid.

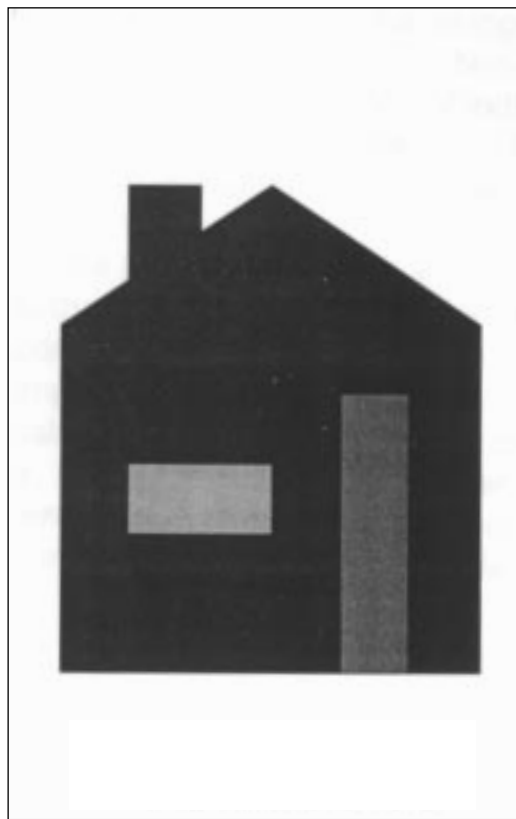

Image

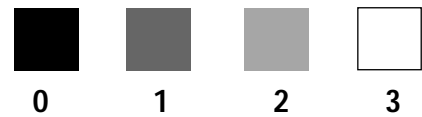

Shading Values

(Don't tell what the picture is!)



Student B: You are Mission Control.



Your job is to assemble the data the spacecraft (your partner) sends you and turn it into an image.

1. Find the square identified by your partner.
2. Color it in to match the Shading Value.
3. What picture did the spacecraft send?

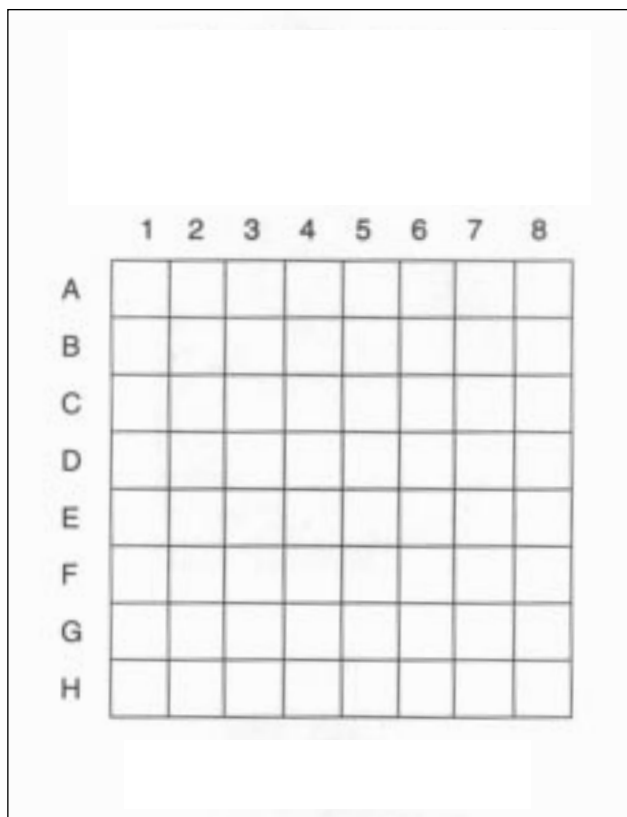

Grid



Shading Values



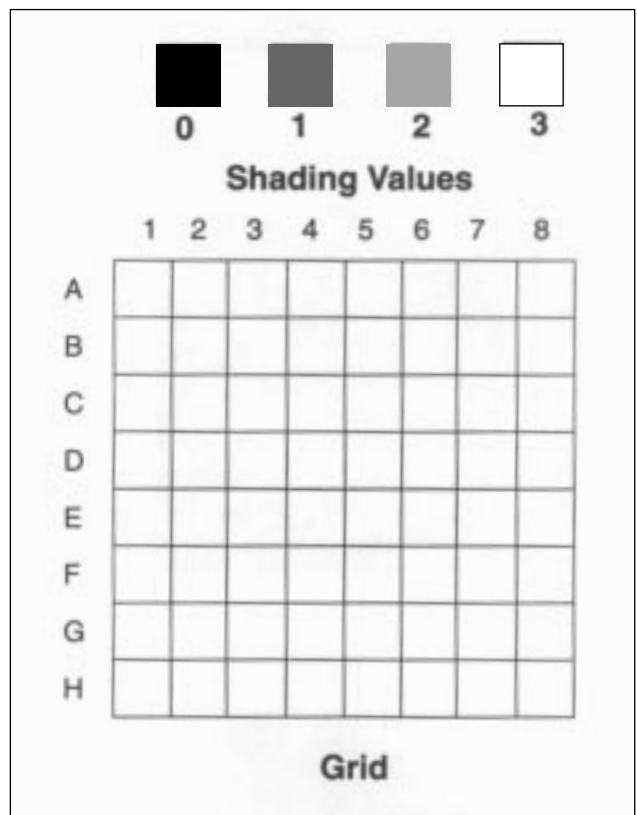
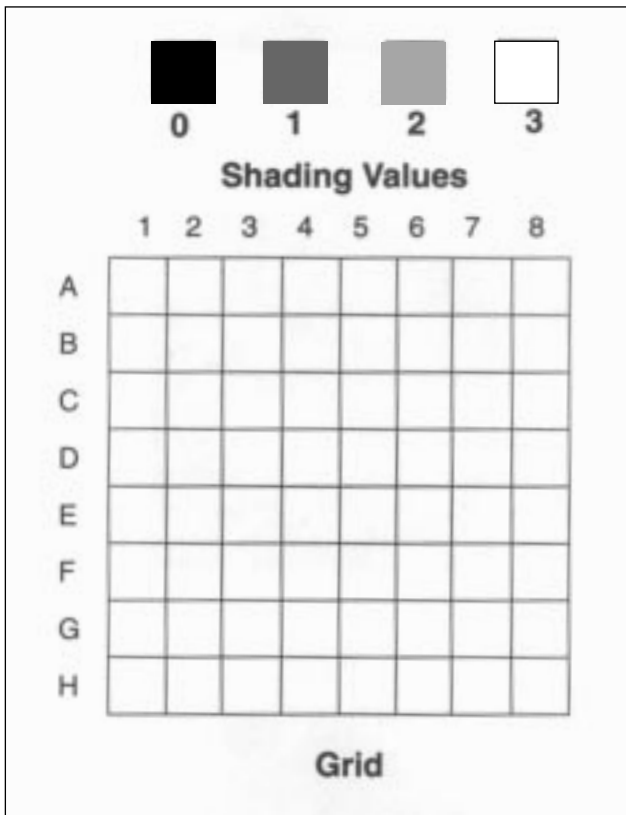
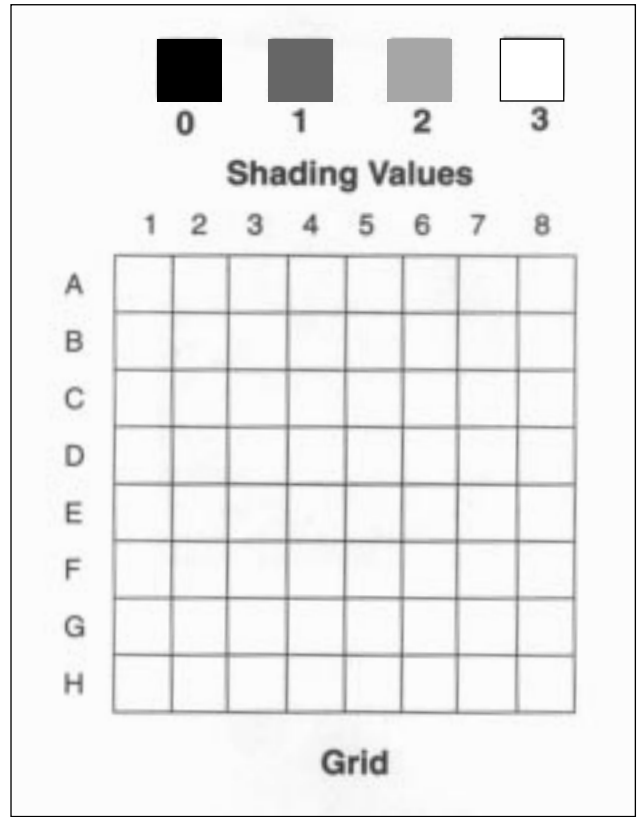
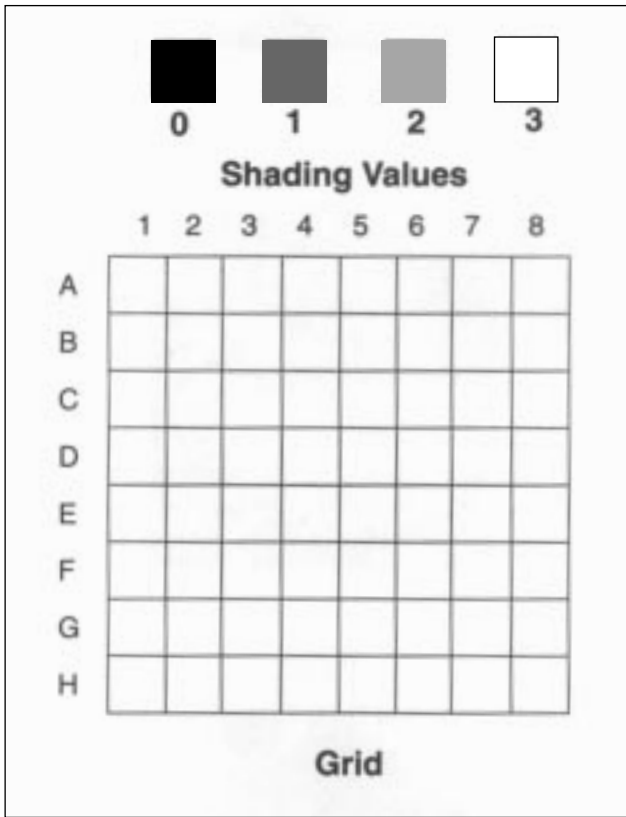

Fact Sheets

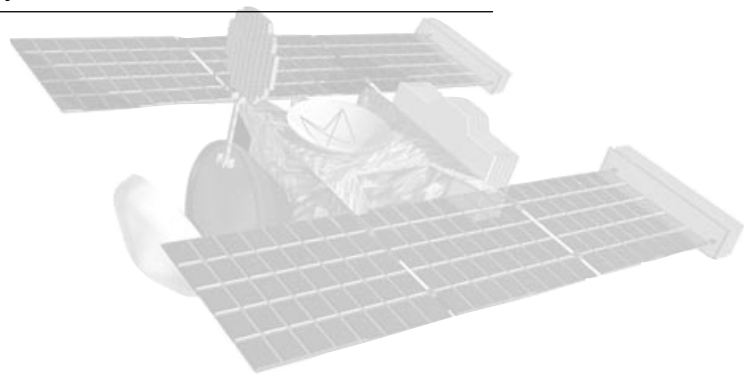

This section contains Fact Sheets for specific activities. They contain background information about comets and the STARDUST mission. Teachers are encouraged to use Fact Sheets as student handouts to support any activity deemed appropriate.

The Fact Sheets included are:

- ◆ Impact Crater Fact Sheet
- ◆ Comet Fact Sheet
- ◆ Kuiper Belt/Oort Cloud Fact Sheet
- ◆ STARDUST Mission Fact Sheet
- ◆ Aerogel Fact Sheet

Impact Crater Fact Sheet

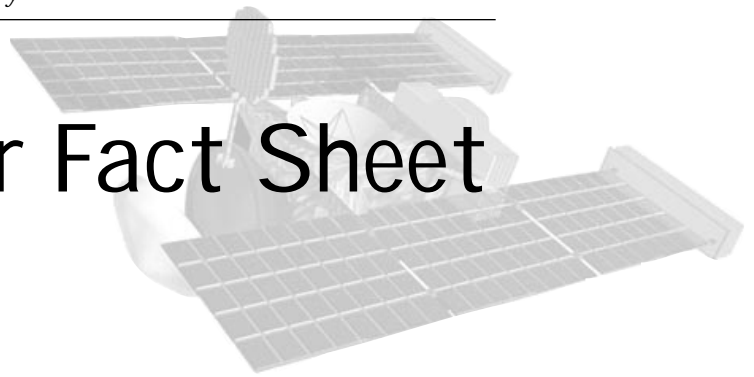

What is an Impact Crater?

Impact craters are marks found on every solid body in the Solar System, like planets and moons. Even asteroids are pitted with craters. When an object slams into a planet, it hits the surface very hard and explodes. Rock and dust fly everywhere. The object that hits the planet is called an impactor. The impactor breaks apart because of the force of the impact, and the impact explosion leaves a round hole or crater in the surface of the planet.

Crater Parts

Walls-The sides of the bowl. Walls can be very deep. They may look like steps, or walls can be shallow. If a crater has shallow walls, then the hole was filled or eroded somehow.

Floor-The bottom part of the impact site (the hole). It may be the shape of a bowl, or it may be flat. This part is often lower than the surrounding surface.

Rim-The highest point along the edge of the hole.

Ejecta-The debris that shoots, or ejects, out of the impact site when the crater forms. There is a lot of ejecta close to the crater, so it is thick. The ejecta gets thinner the farther away it is from the crater. The explosion creates debris as it crushes, heats, and melts the rock.

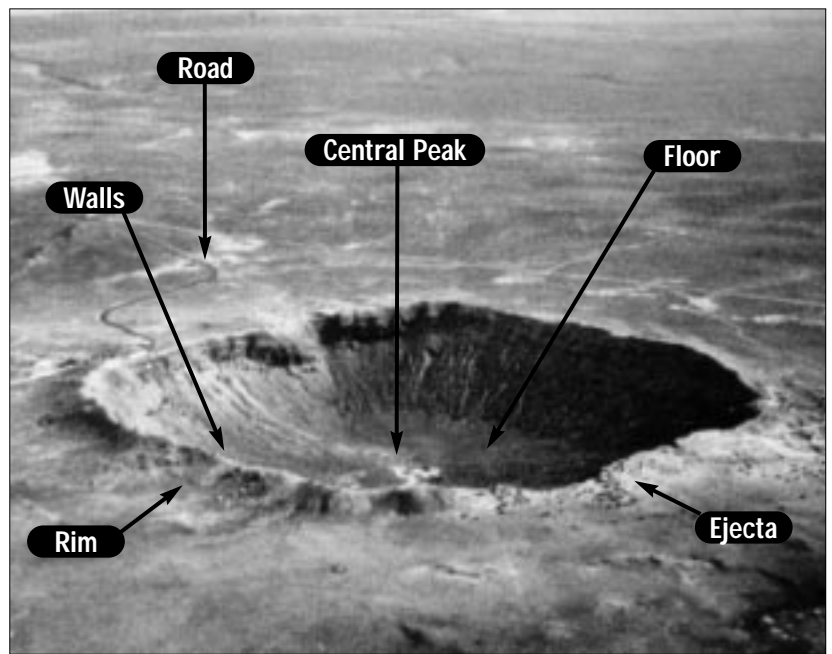

This image shows the Barringer Crater (commonly called Meteor Crater), which is located in the state of Arizona. The crater is 1.2 km across. It is the best preserved crater in North America.

Rays-The bright streaks that start at the rim of the crater and extend outward.

Central Peak-A small mountain that forms at the center of the crater in reaction to the force of the impact. Only really large craters, typically more than 40 km across, can have a central peak. These craters are the size of large cities.



What Changes the Shape of a Crater?

Initially craters have a crisp rim and blankets of ejecta around the sides. The actions of wind, water, lava flows, and plate tectonics can alter the appearance of a crater. Wind can blow away debris around the crater. Rivers and floods can erode the crater's walls and rim. Lava flows can fill in the crater and make the rim smoother. Another impactor may come along and give the crater its own crater. Other impactors can partially or completely destroy an older crater.

Craters and Surface Age

The older a surface is, the more time impactors have to hit it. Really old surfaces have so many craters that it would be difficult to tell if another impactor hit them. Little of the surface is smooth. Most cratering took place right after the planets and moons formed. Places like Earth's Moon and the planet Mercury have heavily cratered, old surfaces.

Younger surfaces have smoother, less cratered surfaces. What makes the surfaces smoother? You will find out one

cause in the activity Go with the Flow. Earth has few craters, due to the features and processes on our planet. Plates that make up Earth's crust move, causing volcanoes or forming mountains. This and other processes erase signs of craters here on Earth and on other planets and moons.

Many worlds have surfaces of different ages. Parts of our Moon are heavily cratered. Other parts are smoother, because lava flows have erased the craters. The ages of the different parts of a planet's surface can be estimated by the number of craters on it.

What Are Comets?

A common theory about comets is that they are dirty snowballs of frozen ices and rock. We know they contain water ice, frozen carbon dioxide, ammonia and methane ice, rocky materials, and organic (carbon-based) materials. Some scientists think that the center, or **nucleus**, of a comet is solid. Others think the nucleus is not solid enough for a spacecraft landing. There is much about comets we do not know.



Comet Fact Sheet

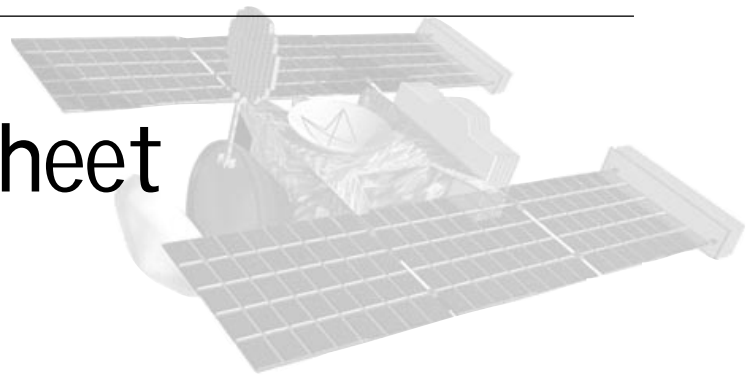

Why Study Comets?

Comets interest scientists because they are the oldest, most primitive objects in the Solar System. They are remnants from the nebula which formed our Solar System. These remnants may have served as building blocks in the formation of planets in our Solar System as well as around other stars. They are organically rich, providing ready-formed molecules that could originate life. The volatile elements (ices) comets contain can play a role in forming atmospheres and oceans. In addition, a high-velocity impact may cause major changes in atmospheres and affect ecosystems, possibly including the extinction of the dinosaurs. Scientists want to study particles from these cosmic travelers more closely for information that can shed light on the formation of Earth, our Solar System, and other planetary systems.

Comet Orbits

Most comets follow long, eccentric orbits around the Sun, spending most of their time traveling in the outer reaches of our Solar System. Comets traveling beyond Jupiter's orbit are usually tailless and difficult to see. Once the comet reaches the inner Solar System, the heat from the Sun begins to make the icy materials **sublime** (turn from solid ice to gas).

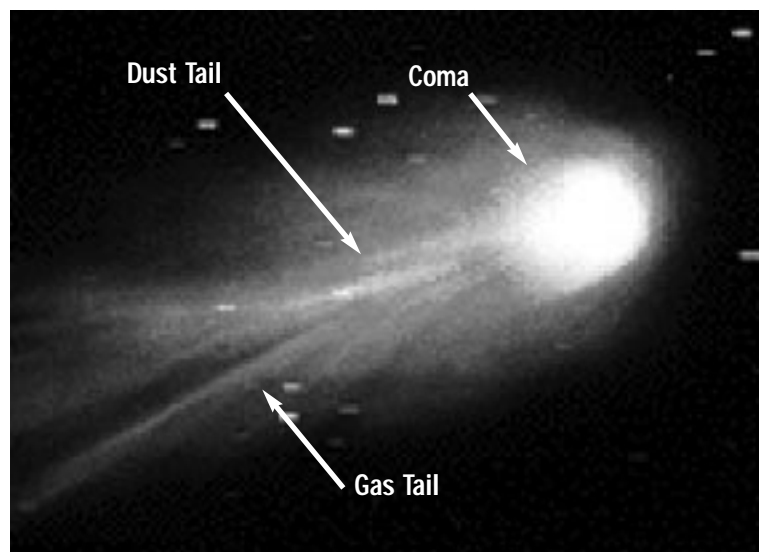

Comet Halley

Parts of a Comet

The Sun's heat causes dust, small rocky particles, and gas to form a bright, spherical cloud, the **coma**, around the dark **nucleus**. Scientists currently think that the nuclei of most comets are generally the size of a city. Charged particles streaming from the Sun in the solar wind "blow" the coma of the comet, pushing it away from the Sun, forming two **tails**, a yellowish dust tail and a blue tail of gas particles.



Where Do Comets Originate?

Comets reside in an area past the orbit of Neptune and Pluto in the Kuiper Belt. They are so far away and so small and dark that astronomers have difficulty detecting them. Occasionally, a gravitational disturbance causes one of these bodies to begin a long journey toward the inner Solar System, orbiting the Sun.

The orbit of a comet can be altered by the gravitational field of Jupiter. When this

happens the comet's original orbit of hundreds or thousands of years changes paths, and shortens. Such a comet might end up catapulting into the Sun, get flung out of the Solar System entirely, or hit Jupiter like comet Shoemaker-Levy 9 did in 1994. Jupiter's gravitational pull commonly shortens a comet's orbit, bringing it into the inner Solar System more often. Comet Wild 2 (pronounced "Vilt," after the Swiss astronomer Paul Wild) is such a comet.



Kuiper Belt and Oort Cloud Fact Sheet

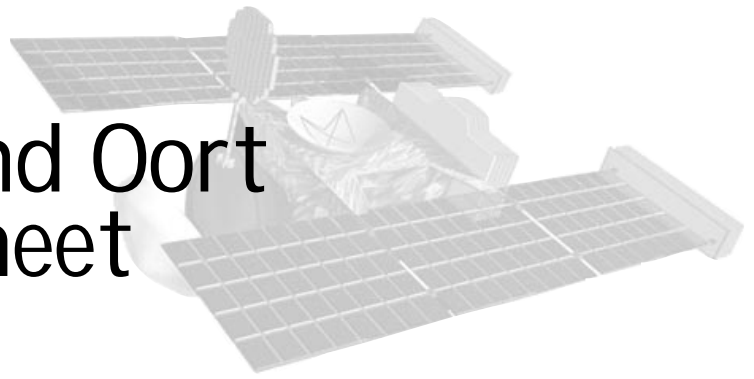

What Is the Kuiper Belt?

The Kuiper Belt is a belt of asteroids on the outer reaches of the solar system. In 1951, Gerard Kuiper proposed the theory that there is a disk-shaped region past the orbit of Neptune roughly 30-100 AU from the Sun containing small, icy bodies. Only a few objects have been found in it, but it may contain millions of chunks of planetary debris.

The Kuiper Belt holds significance for the study of the planetary system on at least two levels. First, it is likely that the Kuiper Belt objects are extremely primitive remnants from the early accretional phases of the solar system. Second, it is widely believed that the Kuiper Belt is the source of short-period comets. Short-period comets have orbital periods of less than 200 years. The Kuiper Belt acts as a reservoir for these bodies in the same way that the Oort Cloud acts as a reservoir for the long-period comets.

Occasionally, the orbit of a Kuiper Belt object will be disturbed by the interactions of the giant planets in such a way that the object crosses the orbit of Neptune. It will then very likely have a close encounter with Neptune sending it out of the Solar System or into an orbit crossing those of the other giant planets or even into the inner Solar System.

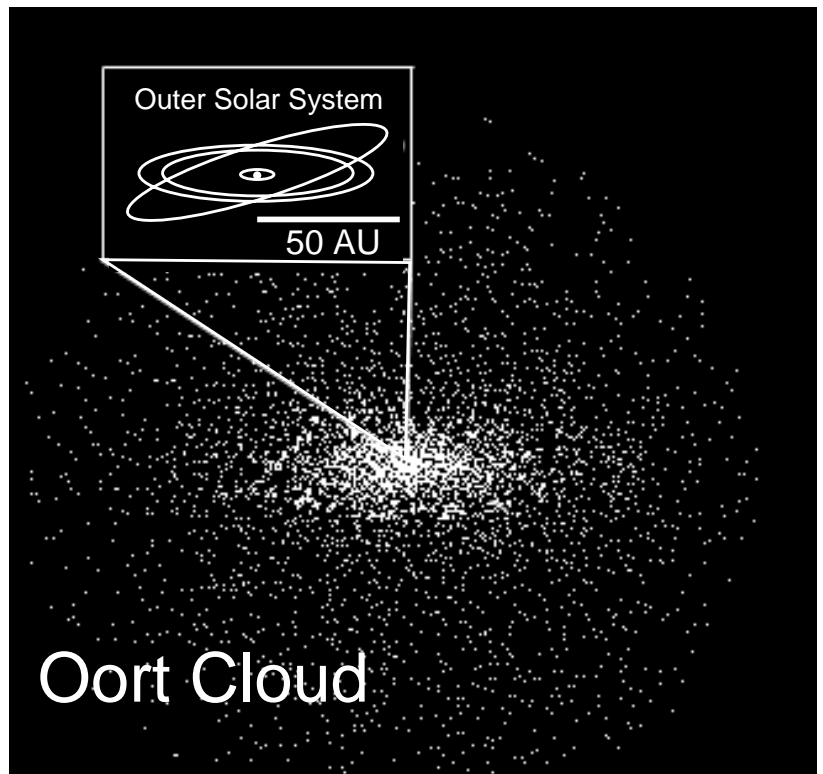

The Oort Cloud is a place where comets originate. An AU is an astronomical unit, the distance from Earth to the Sun.



What is the Oort Cloud?

In 1950, Jan Oort noted that no comet has been observed with an orbit that indicates it came from interstellar space, there is a strong tendency for aphelia of long-period comet orbits to lie at a distance of about 50,000 AU, and there is no preferential direction from which comets come. He proposed that comets reside in a vast cloud at the outer reaches of the Solar System. This became known as the Oort Cloud and is a spherical cloud of ice. Long-period comets, those having orbital periods greater than 200 years, were once thought to have fallen into the inner Solar System where the Sun would heat the ice and it would transform into a comet.

Statistics imply that the Oort Cloud may contain as many as one trillion

comets and may account for a significant fraction of the mass of the Solar System. Unfortunately, since the individual comets are so small and at such large distances, we have no direct evidence about the Oort Cloud.

Differences in Object Formation

It seems that the Oort Cloud objects were formed closer to the Sun than the Kuiper Belt objects. Small objects formed near the giant planets would have been ejected from the Solar System by gravitational encounters. Those that didn't escape entirely formed the distant Oort Cloud. Small objects formed farther out had no such interactions and remained in the Kuiper Belt.



STARDUST Mission Fact Sheet

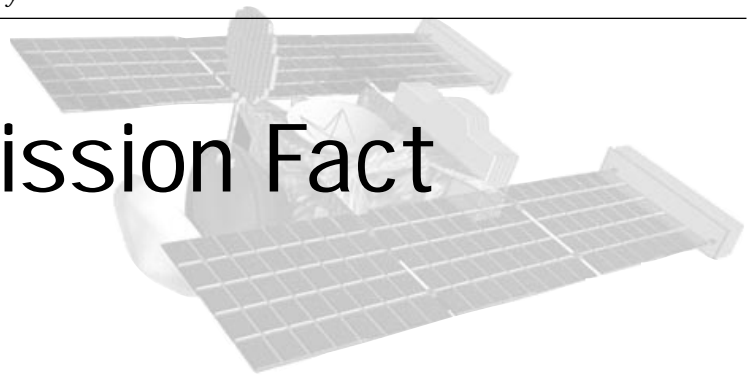

The STARDUST Mission

STARDUST is a small spacecraft that will rendezvous with Comet Wild 2, (pronounced "Vilt" after its Swiss discoverer professor Paul Wild) in 2004. It is the first spacecraft to capture and return cometary dust to Earth for analysis. The spacecraft was launched in February 1999 on board an expendable launch vehicle and rendezvous with Comet Wild 2 in January 2004, coming within 150 kilometers (93 miles) of the comet's nucleus. The particles STARDUST will return are made of ancient material that formed our Sun and planets. What we learn about Comet Wild 2 will probably reshape our understanding of how our Solar System—and perhaps even life—formed.

Comet Wild 2

Jupiter changed Comet Wild 2's orbit in 1974 when the comet made a close approach to the gas giant. A predictable six-year orbit made Wild 2 a good target for the STARDUST mission. Also, Wild 2 is a pristine comet - one that is close to its

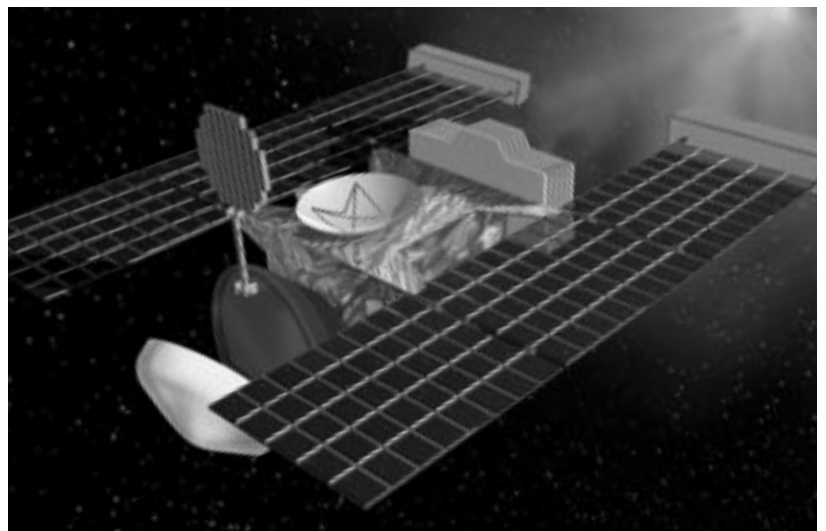

original state. Every time a comet travels near the Sun it loses gas and dust. Wild 2 will only have made 5 passes around the Sun by the time STARDUST reaches it. The fewer the passes a comet makes near the Sun, the less altered it is from its original state. The more pristine a comet is, the more clues it may reveal to scientists about the formation of the Solar System and possibly life itself.



Key STARDUST Dates

1974	Comet Wild 2 orbit altered by Jupiter, bringing it into the inner Solar System in pristine condition
January 1978	Paul Wild discovers Comet Wild 2
1995	NASA selects STARDUST mission
February 1999	STARDUST Launch
March 2000 - May 2000	First Interstellar Dust Collection
January 2001	Earth flyby
July 2002 - December 2002	Second Interstellar Dust Collection
January 2004	Wild 2 Encounter
January 2006	Sample Return Capsule returns to Earth



STARDUST Spacecraft Fact Sheet

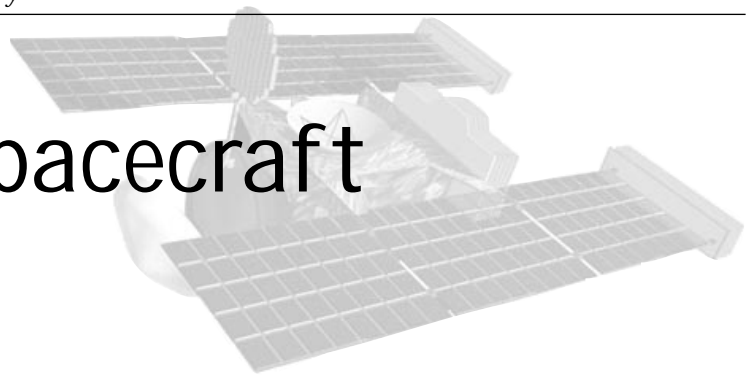

The STARDUST spacecraft is small, measuring the 1.7 meters in length - about the size of an average teacher's desk. Its total weight is 380 kilograms - about the weight of a subcompact car - including propellant needed for space maneuvers. The parts of the spacecraft fall into two categories: science instruments or spacecraft operations.

SCIENCE INSTRUMENTS

Aerogel Dust Collector

The dust collector is a two-sided, aluminum tube grid array that deploys from the Sample Return Capsule. The grid contains blocks of aerogel that are 1 to 2 centimeters thick. Aerogel, also known as "blue smoke" or "solid smoke," is a strong, lightweight, exotic material with the lowest density of any solid. Aerogel is 99% air and 1% silicate dioxide (similar to glass).

When the STARDUST spacecraft flies through the coma, or head, of the comet, the collector will deploy from the Sample Return Capsule (SRC). Cometary particles will hit the aerogel at nearly 6 times the speed of a rifle bullet. The aerogel traps these cosmic bullets without damaging them.

The dust collector will deploy four separate times throughout the seven-year mission. One side will collect interstellar

Encounter Configuration

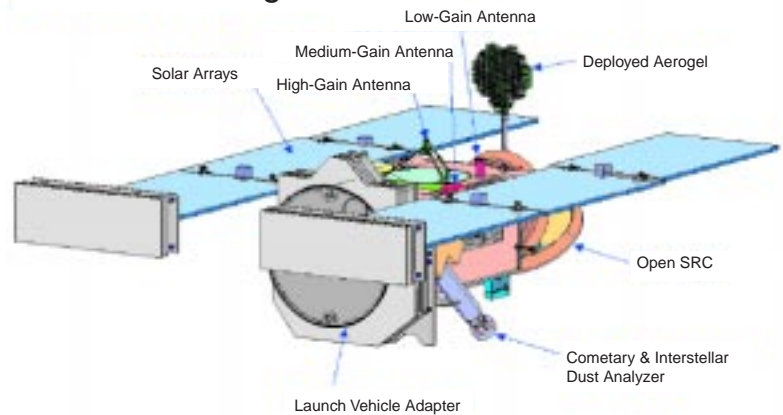

STARDUST Spacecraft

dust and the other side will collect comet particles.

Sample Return Capsule (SRC)

The SRC stores the samples of comet particles and interstellar dust. It separates from the spacecraft just before encountering Earth. The heat shields protect the capsule from burning up when the SRC reenters Earth's atmosphere. Three kilometers from hitting the ground, a two-part parachute system opens. The capsule will gently touch down in a dry lake bed in Utah, where it will be retrieved and the samples studied.



Cometary and Interstellar Dust Analyzer (CIDA)

The CIDA is a mass spectrometer. It analyzes the chemicals found in the comet and interstellar dust when they enter the instrument. Once a particle enters the CIDA, it separates into smaller pieces. The heavier pieces move more slowly than the lighter pieces do, passing sensors at different times. The difference in flight time allows scientists to calculate the mass of the particle.

SPACECRAFT OPERATIONS

All other instruments on board operate the spacecraft. These include:

- ◆ Navigation Camera,
- ◆ Dust Flux Monitors,
- ◆ Solar Array Panels, and
- ◆ three antennas.

Navigation Camera (NC)

The camera navigates the approach to the comet for proper flyby distance. The challenge is to get near the nucleus to collect enough dust. The camera periscope can look over the dust shield during the approach. A scanning mirror rotates to keep the comet in view during flyby. This rotating mirror is some distance from the actual camera lens. The forward-looking mirror has a thick aluminum coating to protect it from impacting particles. The mirror facing away from the particle stream has a nickel coating that produces better images, but flakes off during particle impacts.

The camera also takes pictures through colored filters. These images will help scientists construct a 3-D map of the comet nucleus, and identify gases jetting from

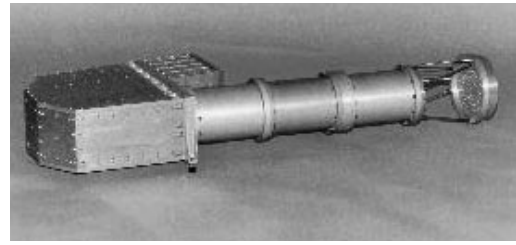

Cometary and Interstellar Dust Analyzer

the nucleus. The NC is mounted on a platform called the deep space bus. Layered, metallic-gold blankets protect the sensitive instruments from the extreme temperatures of space and impacts.

Dust Flux Monitors

Three dust shields protect the spacecraft. They use small vibration sensors to detect large impacting particles. The monitors will determine how hazardous particles from the first encounter with the comet will be.

Solar Arrays

Two wing-like solar array panels power the spacecraft. The arrays are long, lightweight grids containing thousands of solar cells, which tilt to face the Sun. Solar cells are thin, circular wafers that create electricity when light shines on them.

Antennae

STARDUST has three antennas to transmit and receive data. In addition to comet data, the antennas will transmit commands from mission control to navigate and operate the spacecraft. The high-gain antenna sends the most data in the shortest amount of time. If one antenna should fail, mission control will still be able to communicate with the spacecraft.



Aerogel Fact Sheet

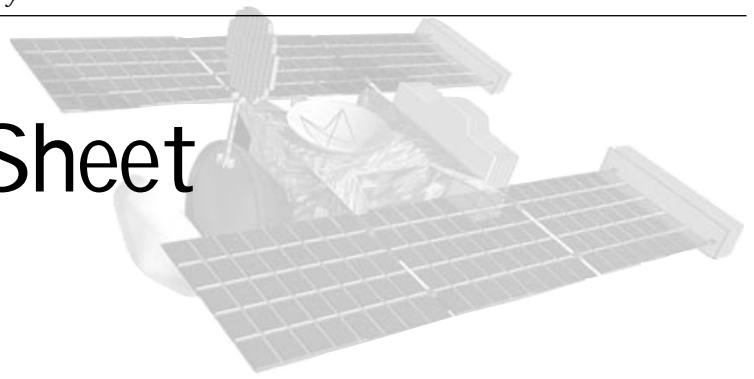

At first sight, aerogel resembles a hologram. It is commonly called “blue smoke” or “solid smoke.” This exotic material has the lowest density of any known solid: it is 99% air. It is 1,000 times less dense than glass. The other percent is made of silica dioxide, a substance used to make glass.

Amazingly lightweight and strong, a block of aerogel the size of a human may weigh less than half a kilogram (less than a pound), yet support the weight of a subcompact car (about 454 kilograms, or 1,000 pounds). An inch of aerogel has the same insulating power as 6 inches of fiberglass and can withstand temperatures up to 1,400° C (2,552° F).

In the photo, scientist Peter Tsou holds a block of aerogel that he made by hand. Aerogel starts as a silica dioxide gel, similar to gelatin you might eat. A process called supercritical drying removes the liquid without collapsing the gel.

When the STARDUST spacecraft flies through the comet’s coma, the cometary particles will hit the aerogel at hypervelocities up to 6 times the speed of a rifle bullet. Aerogel will trap these cosmic bullets, keeping them intact so they are not damaged by the impact.

Particle Tracks

When hypervelocity particles are captured in aerogel they produce narrow, cone-shaped, hollow tracks in the highly transparent aerogel. The cone is largest where the particle entered the aerogel.

Scientists follow the cone to its point to collect the intact particle. The conical tracks indicate the direction which the particles were traveling when they entered the aerogel. In this image, the particle entered the aerogel from the bottom right and stopped in the upper left corner.



Vocabulary

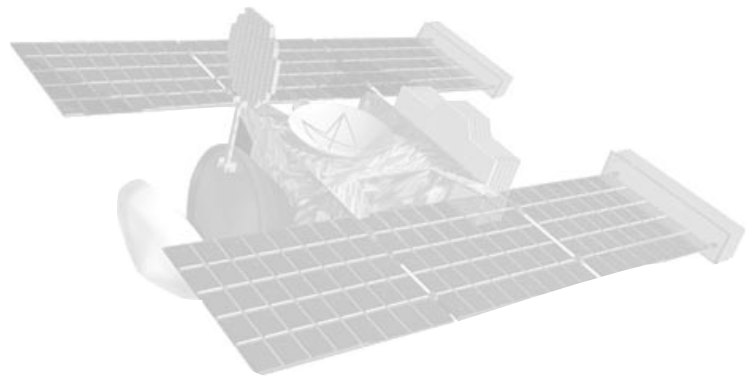

Aerogel - A silicate dioxide material with the lowest known density of any solid, made of 99% air. Sometimes referred to as solid blue smoke, aerogel is lightweight, strong, and has more insulating power than fiberglass. The STARDUST spacecraft will use aerogel to capture microscopic, high-velocity particles from the coma of a comet and interstellar dust.

Asteroid (also "planetoid") - A rocky body orbiting the Sun, usually greater than 100 m in diameter. Most asteroids orbit between Mars and Jupiter, roughly 2 - 4 AU from the Sun.

Astronomical unit (AU) - One AU is equal to the average distance between the Sun and Earth, approximately 150 million kilometers (93 million miles).

Central Peak - A small mountain that forms at the center of a crater more than 40 km across in reaction to the force of the impact.

Circle - A geometric shape, where all points are the same distance from the center.

Coma - A cloud of dust and gas that forms around a comet's nucleus as the Sun heats it.

Comet - A small icy object with highly eccentric orbits around the Sun. See long-period and periodic comets.

Crater - Impact craters are the result of an asteroid, comet, or planetary body hitting the surface of another planetary body. The resulting explosion leaves a round hole or crater.

Density - The mass of a substance for a given volume.

Eccentricity - A numerical value for the shape of an orbit ranging from 0 (zero) which equals a circular orbit to nearly 1 (one) which equals a long, flattened orbit. Planets (except Pluto), moons, asteroids, and short-period comets have eccentricity values close to 0 (zero). Long-period comets have eccentricity values of 0.5 or more.

Ellipse - An oval, where all the points on the curve form the sum of the distances from two fixed, or focal points.

Ejecta - The debris that shoots out of the impact site when a crater forms.

Feedback Loop - Information flowing two ways, in the case of STARDUST between mission control operators and the spacecraft.

Floor - The bottom part of an impact crater. It can be flat or rounded and is often lower than the surrounding surface of the planet or moon.

Focal Points - See definition for ellipse.

Gravity - Force of attraction between matter, proportional to its mass. Gravity holds us on Earth and keeps the planets orbiting around the Sun. Just as Earth pulls on you, you pull on Earth; however, the effect of your pull on Earth is negligible since Earth's mass is so much bigger.

Gravity Assist - The process of flying close to a planet in such a way as to gain energy and deflect a spacecraft onto a different course. The spacecraft accelerates, while the planet slows down a minute amount.



Kuiper Belt - A disk-shaped region roughly 30 to 100 AU from the Sun (past the orbit of Neptune) containing many small icy bodies. It is believed to be the source of short-period comets.

Long-period comets - A comet with an orbital period of more than 200 years. Examples: Comet Hale-Bopp, 4,000-year orbit; Comet Hyakutake, more than a 65,000-year orbit.

Mass - The measure of an object's inertia, i.e., how heavy it is. Mass is not the same as weight, which measures the gravitational force on an object.

Magnitude - A numerical value for the brightness of a celestial object. The brighter an object is in the sky, the smaller its magnitude.

Meteor - A bright streak of light in the sky caused by a meteoroid or a small icy particle entering Earth's atmosphere. It is also known as a "shooting star" or "falling star." Meteor showers sometimes occur when the Earth passes through debris left behind by an orbiting comet.

Meteorite - The rocky remains of meteoroids that survive the fiery journey through Earth's atmosphere and land on Earth.

Meteoroid - A small rocky object orbiting the Sun less than 100 m in diameter. Meteoroids are smaller than asteroids.

Nucleus - The solid part of a comet, made of ices and rock. As the nucleus approaches the inner solar system, its ices melt, creating a much larger coma of dust and gas which surrounds it. The true nucleus of a comet (Halley) has only been seen once, by the spacecraft Giotto.

Oort Cloud - A huge spherical "cloud" that extends from beyond the orbit of Neptune and Pluto, half way out to the nearest star. It may contain a trillion or more comets orbiting the Sun. This is thought to be the source of long-

period comets.

Orbit - The path a planetary body makes as it revolves around the Sun. The orbit of a comet tends to be far more elliptical than planets.

Particle - A tiny, or minute, quantity of a substance.

Perihelion - The point where an object orbiting the Sun is closest to the Sun.

Periodic or short-period comets - A comet with an orbital period of less than 200 years. Short-period comets fade over time as more and more of their ices melt with each passage of the Sun. Examples: Comet Halley, 76-year orbit; Comet Encke, 3.3-year orbit; Comet Wild 2, 6.2-year orbit.

Rays - The bright streaks that start at the rim of the crater and extend outward.

Rim - The highest point along the edge of a crater hole.

Spectrometer - An instrument used to obtain and record a spectrum of an astronomical object. A spectrum is a series of colors that is produced when light is spread out in order of wavelength. Scientists use spectra to determine the chemical composition of an object.

Sublimation - The process of an ice turning from a solid state directly to a gas state, without changing to a liquid first.

Tail - A long trail of dust and gas that extends out from the coma of a comet. The tail always points away from the Sun! These appendages come in a variety of shapes and lengths that can cover a significant portion of the sky.

Wall - The sides of the bowl of a crater.



Resources

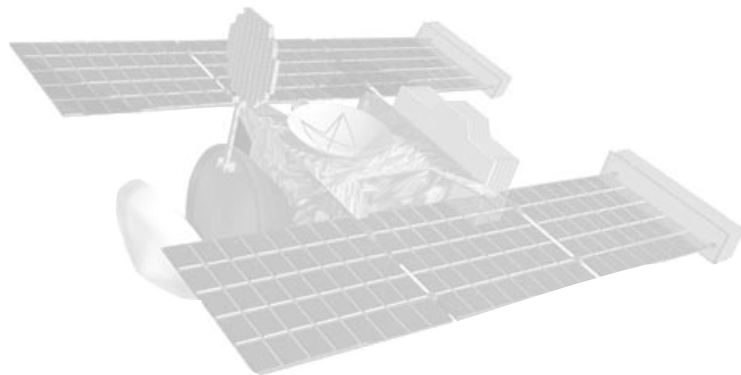

The following is a list of websites, organizations, and magazines teachers can consult for more information about the STARDUST mission, comets, and other small bodies. Happy hunting!

Websites

Asteroid and Comet Page

NASA and National Space Science Data Collection
<http://nssdc.gsfc.nasa.gov/planetary/planets/asteroidpage.html>
http://nssdc.gsfc.nasa.gov/planetary/planetary_home.html
Contains fact sheets, FAQs, photo galleries, future mission information, and offers CD-ROMs

Comets and Meteor Showers

<http://medicine.wustl.edu/~kronkg/index.html>
You've probably seen a "shooting star" flash briefly across the sky on a clear summer night. This site will help you learn about these and other cosmic interlopers. Plenty of pictures and hints for observing are among the highlights here.

Comet Observation Home Page

<http://encke.jpl.nasa.gov/>
Check this site for the latest comet observations, finder charts, and background information on comets.

Comet Hale-Bopp Home Page

<http://www.halebopp.com>
Be sure to visit the official Comet Hale-Bopp page and find out just how Dr. Alan Hale discovered this mysterious cosmic visitor! HINT: It wasn't from some huge observatory ...

JASON Foundation for Education

<http://www.jasonproject.org/front.html>
Visit this site for the latest expedition information and ways to get involved.

JPL Comet Hale-Bopp Page

<http://www.jpl.nasa.gov/comet/>
Chronicles one of the brightest comets ever observed. Clear explanations and numerous pictures let you keep tabs on this visitor from deep space.

JPL's Shoemaker-Levy 9 homepage

<http://www.jpl.nasa.gov/sl9/>
Contains images of comet Shoemaker-Levy 9's impact with Jupiter, including many from spacecraft Galileo. This website was visited more during the week of the impact with Jupiter than any homepage to date.

NASA Spacelink

<http://spacelink.msfc.nasa.gov/home.index.html>
Offers educational materials, software, and images on aerospace topics. Special features for teachers that sign-up for accounts. Check for upcoming events for educators.

National Space Science Data Collection (NSSDC) Homepage

<http://nssdc.gsfc.nasa.gov/planetary/>
Offers latest news in planetary science, CD-ROM collections, and information on all comets.

Night of the Comet

NASA, SOFIA, and Internet in the Classroom
<http://www.comet.arc.nasa.gov/comet/>
Chronicles amateur astronomers from around the world sharing information and photographs of Comet Hyakutake.

Omniplex at Kirkpatrick Science and Air Space Museum

<http://www.cpb.uokhsc.edu/okc/kirk/kirkmap.html>
Four museums are housed at this Kirkpatrick Center site.

Sky On Line Homepage

<http://www.skypub.com/>
This is the Sky & Telescope magazine homepage. Offers news bulletin, Sky Publication Catalogs, Comet Page, tips on backyard astronomy, star parties and events, links to Internet telescopes, clubs, and observatories.

Space Image Libraries

NASA Aerospace Education Specialists Site
<http://www.okstate.edu/aesp/image.html>



Offers latest pictures on rockets, probes, and spacecraft, Hubble Telescope, NASA-related sites, Space Agencies, Astrophotography, special missions, observatories, and events.

STARDUST Mission homepage

<http://stardust.jpl.nasa.gov/>

Includes information on the mission, spacecraft, and comets, and educational materials with terrific links to other sites.

Non-Web Resources

Organizations

Astronomical Society of the Pacific: ASP has a free quarterly educational newsletter, a catalog full of great educational items. Project ASTRO's Universe at Your Fingertips comprehensive and ready-to-use collection of classroom activities, teaching ideas, and annotated resource lists is a must-have resource for every school in the country! For around \$30, it is a bargain that cannot be passed up. Call (800) 335-2624 or write to the Astronomical Society of the Pacific, 390 Ashton Avenue, San Francisco, CA 94112.

Challenger Center For Space Science Education: A part of STARDUST's Education Outreach Team, Challenger Center is a not-for-profit organization committed to using the theme of space exploration to create positive learning experiences, foster interest in science, math, and technology, and motivate young people to explore. Challenger Center offers classroom programs and teacher workshops as well as providing a network of over 30 Challenger Learning Centers in partnership with museums, science centers, schools, universities, and communities across North America. For more information write Challenger Center, 1029 N. Royal Street, Suite 300, Alexandria, VA 22314, or call (703) 683-9740.

JASON Foundation for Education: A part of STARDUST's Education Outreach Team, JASON is a non-profit educational organization founded to administer the JASON Project, an educational project begun in 1989 by Dr. Robert D. Ballard following his discovery of the wreck of the RMS Titanic. After receiving thousands of letters from children who were excited by his discovery, Dr. Ballard and a team of associates dedicated themselves to developing ways that would enable teachers and students all over the world to take part in global explorations using advanced interactive telecommunications. For more information write: JASON Foundation for Education, 395 Totten Pond Road, Waltham, Massachusetts 02154 or call (781) 487-9995.

Harvard-Smithsonian Center for Astrophysics: CfA offers broadcast and instructional television programs, in-service and preservice workshops, and a physical science curriculum for elementary students called Project ARIES, among other programs. CfA can be contacted at 60 Garden Street, Cambridge, MA 02138.

Kirkpatrick Science and Air Space Museum at Omniplex: A part of STARDUST's Education Outreach Team, Kirkpatrick Center is the home of four major Oklahoma City Museums: the Air Space Museum, the International Hall of Fame, the Omniplex Science Museum, and the Red Earth Center. For more information write 2100 N.E. 52nd Street, Oklahoma City, OK. 73111 or call (405) 427-5461.

Lunar & Planetary Institute: This branch of the Center for Advanced Space Studies is part of the Universities Space Research Association (USRA) that offers specialized slide sets for educators on a variety of Solar System topics. Contact LPI, Order Dept., 3600 Bay Area Blvd., Houston, TX 77058. Call (281) 486-2172. NASA CORE: The Central Operation of Resources for Educators for NASA-generated materials. CORE, Lorain County JVS, 15181 Rt. 58 South, Oberlin, OH 44074. Call (216) 774-1051, ext. 293 or 294.

National Science Teachers' Association: In addition to hosting wonderful conferences and producing a variety of classroom resources, NSTA coordinates NASA's two primary teacher training programs for elementary and secondary teachers-known as NEWEST & NEWMAST-and the Space Science Student Involvement Program. NSTA, Space Science and Technology, 1840 Wilson Blvd., Arlington, VA 22201-3000. Call (703) 243-7100. National Space Society: With membership comes a subscription to NSS' Ad Astra magazine, a great way to stay in touch with the current events and issues surrounding space exploration. NSS, 600 Pennsylvania Avenue, SE, Suite 201, Washington, DC 20003. Call (202) 543-1900.

Magazines

Astronomy Magazine: Found in most public libraries, this popular astronomy magazine is loaded with articles on current events in astronomy. Write to 21027 Crossroads Circle, P.O. Box 1612, Waukesha, WI 53187.

Sky & Telescope Magazine: Found in most public libraries, this popular astronomy magazine is loaded with articles on current events in astronomy. P.O. Box 9111, Belmont, MA 02178.



